

RS-500/600 Series Doors Installation Manual

**RollSeal
1733 County Road 68
Bremen, Alabama 35033
256-287-7000**

Table of Contents

1	Warnings (Avertissements).....	4
2	Limited Warranty.....	10
3	Use of Equipment.....	11
4	Physical Description.....	11
5	Differences between a RS-500 and RS-600 Series Door.....	11
6	Operator Options.....	12
7	Ratings and Specifications RS-500/600 Series (Brother Motor).....	13
8	RS-500 Series Door (Brother Motor).....	14
9	RS-600 Series Door (Brother Motor).....	15
10	RS-500 Series Door with Optional Condensation Management System.....	16
11	RS-600 Series Door with Optional Condensation Management System.....	17
12	Installation of RS-500/600 Series Doors.....	18
	12.1 Tools Required.....	18
	12.2 Overview.....	18
	12.3 Adjusting the Door Framing or Clear Opening.....	18
	12.4 Attachment Points of Door.....	19
	12.5 Assembly of Tracks.....	20
	12.6 Assembly of Tracks to the Head Unit.....	21
	12.7 Infrared Sensor Connectors (Brother Motor Option Only).....	22
	12.8 Fastening Door Assembly to Clear Opening.....	22
13	Manaras Motor Mounting to RS-500/600 Series Doors.....	24
14	Manaras Manual Operation.....	31
15	Manaras Motor Operation.....	32
	15.1 Adjustment of Limit Switches.....	33
16	Wiring Options to the Manaras Operator Terminal Block.....	34
	16.1 Wiring Switches.....	34
	16.2 Two (2) Position Switch.....	34
	16.3 Three (3) Position Switch.....	35
	16.4 Three (3) Position Switch With Key Lock.....	35
	16.5 BEA Receiver.....	36
17	Manual Chain Hoist.....	37
	17.1 Chain Hoist Installation.....	37
	17.1.1 Removal of the First Safety Bracket.....	37
	17.1.2 Chain Hoist Mechanism Installation.....	38
	17.1.3 Removal of Second Safety Bracket After Hoist Is Installed and Secured.....	38
	17.2 Operation of the Manual Chain Hoist.....	39
18	Brother Operator.....	40
19	Installation of RS-500/600 Series Doors Freezer Kit.....	40
	19.1 Tools Required.....	41
	19.2 Overview.....	41
20	Installation of Condensation Management System and Ducts.....	41
	20.1 Wiring the Condensation Management System for RS-500-600 Series Doors.....	42
21	Connecting Electrical Power to RS-500/600 Series Doors.....	42
22	Electrical Connections for RS-500/600 Cooler Door.....	42
	22.2 Connection of Controller to Head Unit.....	42

22.3	Installation of Prewired Switches	43
22.4	Power Connection with Disconnect	43
22.5	Preparation for Operation.....	44
23	Operation of RS-500/600 Series Doors With Brother Operator	45
23.1	Operation of a Standard RS-500/600 Series Door:	45
23.2	Operation of RS-500/600 Series Door with Optional Freezer Kit	46
24	Limit Switches.....	46
25	Manual Operation RS-500/600 Series Door With Brother Operator	47
26	Adjustment of Brake (Brother Motor Only)	48
27	Door Panel Adjustments	49
28	Removal of Existing Panel	50
29	Installation of Replacement Panel	50
30	Cleaning Panels and Windows	52
31	Optional Door Features.....	52
31.1	Warning Indicator Light (Optional Feature)	52
31.2	Egress Strap (Optional Feature)	52
31.3	Egress Buzzer (Optional Feature)	52
31.4	Soft Tension Pipes (Optional Feature)	52
31.5	Impact Resistant Tension Pipes (Optional Feature)	52
32	Emergency Egress (Optional Feature)	53
32.1	Installation.....	53
32.2	Exiting (Opening) The Door	53
32.3	Resetting (Closing) The Door	54
33	Egress Strap Removal/Re-Installation	55
33.1	Removal	55
33.2	Installation.....	55
34	Removing and Replacing Floating Magnets or Velcro.....	56
35	RS-500/600 Series Door Wiring Diagram (Brother Motor Only)	61
36	RollSeal Smart Controller Wiring Diagram (Brother Motor Only).....	62
37	SC-325 Wiring Diagram.....	63
38	RollSeal CMS (Condensation Management System) Wiring Diagram	64
39	Wiring Optional Accessories	65
39.1	Wiring Falcon XL and EX Motion Detectors	65
39.2	Wiring Falcon IS40 Infrared and Microwave Sensor.....	65
39.3	Wiring the IRIS Infrared and Microwave Sensor.....	66
39.4	Wiring the Matrix2 Loop Sensor.....	66
39.5	Wiring BEA Receiver and Brother Motor.....	67
40	Replacement Parts and Optional Accessories	68
40.1	SC-325 Controller	68
40.2	SC-650 Controller	69
40.3	Door Replacement Parts and Accessories	70

1 Warnings (Avertissements)

Warning!

Disconnect All Power Sources Before Installing This Equipment. Failure To Disconnect Power Source Can Result In Property Damage, Serious Injury Or Death!

Warning!

Dangerous Rotating Machinery!
Keep Hands, Clothing, Etc. Clear When Operating!
Do Not Operate Without All Guards And Covers In Place!

Warning!

All Wiring Should Be In Accordance with National Electrical Codes Or Other Local Codes.

Warning!

The Installer Is Responsible For Complying With All Relevant Regulations, Such As National Wiring Regulations And Accident Prevention Regulations. Particular Attention Must Be Given To The Cross-sectional Areas Of Conductors, The Selection Of Fuses Or Other Protection, And Protective Earth/Ground Connections!

Warning!

The Voltages In The Power Cables And Certain Parts Of The Drive Can Result In Death. Whenever The Drive Has Been Used, It Must Be Isolated And Disconnected For 5 Minutes Before Any Work Commences.

Danger!

Only Qualified Electrical Personnel Familiar With The Construction And Operation Of This Equipment And The Hazards Involved Should Install, Adjust, And/Or Service This Equipment. Read And Understand This Manual In Its Entirety Before Proceeding. Failure To Observe This Precaution Could Result In Severe Bodily Injury Or Death!

Warning!



Item 4501-6312
(Warning Moving Door Label)
Supplied With Door,
MUST Be Installed
On Inside Of Cooler/Freezer
Beside Door Opening.

IMPORTANT INSTALLATION INSTRUCTIONS

Warning!

To Reduce The Risk Of Severe Injury Or Death:

1. READ AND FOLLOW ALL INSTALLATION INSTRUCTIONS.
2. Do not connect the door operator to the source of power until instructed to do so.
3. Locate the control station: (a) within sight of the door, (b) at a minimum height of 5 feet so small children cannot reach it, and (c) away from all moving parts of the door. Remove all ropes and remove or make inoperative all locks connected to the garage door before installing opener.
4. For products having a manual release, instruct the end user on the operation of the manual release. Where possible, install the door opener 8 feet or more above the floor. For products having an emergency release, mount the emergency release within reach, but at least 6 feet above the floor and avoiding contact with vehicles to avoid accidental release.

IMPORTANT SAFETY INSTRUCTIONS

Warning!

To Reduce The Risk Of Severe Injury Or Death:

1. READ AND FOLLOW ALL INSTRUCTIONS!
2. Never let children operate or play with door controls. Keep the remote control (where provided) away from children.
3. Personnel should keep away from a door in motion and keep the moving door in sight until it is completely closed or opened. **NO ONE SHOULD CROSS THE PATH OF A MOVING DOOR.**
4. Test the door's safety features at least once a month. After adjusting either the speed or the limit of travel, retest the door operator's safety features. Failure to adjust the operator properly may cause severe injury or death. **NEVER GO UNDER A STOPPED, PARTIALLY OPEN DOOR.**
5. For products having a manual release, if possible, use the manual release only when the door is closed. Use caution when using this release when the door is open.
6. **KEEP DOORS PROPERLY OPERATING AND BALANCED.** See Door Manufacturer's Owner's Manual. An improperly operating or balanced door can cause severe injury or death. Have trained door systems technician make repairs to cables, spring assemblies, and other hardware.
7. Install the Entrapment Warning label next to the control button in a prominent location. Install the Emergency Release Marking. Attach the marking on or next to the emergency release.
8. After installing the opener, the door must reverse when it contacts a 1-1/2 inch high object (or a 2 x 4 board laid flat) on the floor.
9. **SAVE THESE INSTRUCTIONS.**

Proposition 65 Warning!

California Proposition 65 Warning: This product can expose you to chemicals, including Lead, which is known to the state of California to cause cancer or birth defects or other reproductive harm. For more information, go to www.p65Warnings.ca.gov/furniture.

French Translated Warnings

Avertissement!

Disjoindre l'énergie de toutes les sources avant d'installer cet équipement.
L'échec à disjoindre la source de puissance peut entraîner des dommages matériels, une blessure grave ou la mort !

Avertissement !

Mécanisme tournant dangereux !
Garder les mains, vêtements, etc. loin quand fonctionner !
Ne fonctionner pas sans toutes gardes et couvertures dans lieu !

Avertissement !

Tout montage sur fil de fer doit être selon codes électriques nationaux ou autres indicatifs régionaux.

Avertissement !

L'installateur est responsable pour conformer avec tout règlement pertinent, telles que règlement et règlement de prévention d'accident de montage sur fil de fer nationaux. L'attention particulière doit être donnée pour les aires sectionnelles transversales de conducteurs, le choix d'elles fusées ou autre protection, et terre / prises de terre protecteur !

Avertissement !

Les tensions dans le pouvoir câblent et certaines parties de la promenade en voiture peuvent résulter dans la mort. Lorsque la promenade en voiture a été utilisé il doit être isolé et détaché pendant 5 procès avant que tout travail commence.

Danger !

Seulement le personnel électrique qualifié avec la construction et opération de cet équipement et les dangers ont enveloppé doivent installer, arranger, et/ou - la révision cet équipement. Lire et comprendre ce manuel en entier avant que procéder. L'échec à observer cette précaution peut résulter dans dommage corporel sévère ou mort !

Avertissement !



Point 4501-6312
(Avertissement Moving étiquette de porte)
Livré avec porte,
doit être installé à
l'intérieur du réfrigérateur / congélateur
côté Ouverture de la porte.

LES INSTRUCTIONS D'INSTALLATION IMPORTANTES



À réduire le risque de blessure sévère ou mort:

1. LU ET SUIVENT TOUTES INSTRUCTIONS D'INSTALLATION.
2. Ne liez pas l'opérateur de porte per la source de pouvoir jusqu'à instruit faire ainsi.
3. Localisez la station de commande: (a) en vue de la porte, (b) à un minimum la hauteur de 5 pieds ainsi petit enfants ne peuvent pas l'atteindre, et (c) loin de tous parties en mouvement de la porte.
4. Pour produits ayant un délivrance manuelle, instruire l'utilisateur final sur l'opération de la délivrance manuelle.

RÈGLEMENTS DE SÉCURITÉ IMPORTANTS



À réduire le risque de blessure sévère ou mort:

1. LU ET SUIVENT TOUTES INSTRUCTIONS!
2. Jamais laisser fonctionner enfants ou mouvoir vivement avec les autorités de porte. Gardez la télécommande (où a fourni) loin des enfants.
3. Le personnel devrait garder loin une porte dans mouvement et subsistance la porte en mouvement dans vue jusqu'à est complètement fermé ou avoir ouvert. **CES AUCUNS DOIVENT CROISER LE CHEMIN D'UNE PORTE EN MOUVEMENT.**
4. Éprouvez les traits de sécurité de la porte au moins une fois par mois. Après qu'arrangeant la vitesse ou la fin de course, retest les traits de sécurité de l'opérateur de porte. Manque à arranger l'opérateur correctement peut causer blessure sévère ou mort.
5. Pour produits ai manuel la délivrance, si possible, utiliser la délivrance manuelle seulement quand la porte est fermée. Précaution d'utilisation à utiliser cette délivrance quand la porte est ouverte.
6. **GARDER LES PORTES CORRECTEMENT QUI OPÈRE ET ÉQUILIBRÉ.** Voir la porte fabricant propriétaire manuel. Un improprement qui opère ou balancé porte peut causer blessure sévère ou mort. Formez les technicien de systèmes de porte faites les réparations per les câbles, réunions de source, et autre quincaillerie.

7. **SAUVEZ CES INSTRUCTIONS.**

2 Limited Warranty

All products are warranted to be free from defects in material and workmanship for a period of one (1) year or 100,000 cycles, whichever occurs first, from the date of purchase if installed and used in strict accordance with the installation instructions. Liability is limited to the sale price of any products proved to be defective or, at manufacturers' option, to the replacement of such products upon their return. No products are to be returned to the manufacturer, until there is an inspection and/or a return-goods authorization (RGA) number is issued.

All complaints should be directed first to the authorized distributor who sold the product. If satisfaction is not obtained or the name of the distributor is not known, write the manufacturer that appears below, directed to the attention of Customer Service Manager.

This limited warranty is expressly in lieu of any and all representations and warranties expressed or implied, including any implied warranty of merchantability or fitness for a particular purpose. The remedy set forth in this limited warranty shall be the exclusive remedy available to any person. No person has authority to bind the manufacturer to any representation or warranty other than this limited warranty. The manufacturer shall not be liable for any consequential damages resulting from the use of our products or caused by any defect, failure or malfunction of our products. (Some areas do not allow the exclusion or limitation of incidental or consequential damages, so the above limitation or exclusion may not apply to you.)

This warranty gives you specific legal rights and you may also have other rights that vary from area to area.

Warrantor:
RollSeal
1733 County Road 68
Bremen, Al 35055
256-287-7000



3 Use of Equipment

The RS-500/600 Series Doors are motorized curtain enclosures for environmental control, ripening rooms, docks/warehouses, car and truck washes, agricultural/horticultural, and coolers/freezers.

4 Physical Description

The RS-500/600 Series Doors are available with multiple features and options such as:

- **Standard Door Sizes:** Refer to Tables 1-4, RS-500/600 Series Standard Dimensions, Sections 0, 9, 10, and 11.
- **Operators:** Manual Chain Hoist, Brother or Manaras Operator.
- **Left/Right/Front Mounting:** The Manaras Operators can be mounted on the left, right, or front. The manual chain hoist can be mounted on the left or right side. The Operator Mounting Side must be selected at the time of order.
- **Left Mounting Only:** The Brother motor can only be mounted on the left side, the associated controller, on the right side.
- **Manaras Operator Voltage Selection:** 1/2 HP, Single Phase: 115V @ 8.6 amp, 230V @ 4.1 amp. 1/2 HP, 3 Phase: 208V @ 2.2 amp, 460V @ 1.1 amp. 1 HP, Single Phase: 115V @ 13.4 amp, 230V @ 6.7 amp. 1 HP, 3 Phase: 208V @ 3.4 amp, 460V @ 1.7 amp.
- **RS-500 with Brother Motor - Controller Standard Input Voltage 115VAC (Must request 230VAC).**
- **RS-600 with Brother Motor - Controller Standard Input Voltage 230VAC.**
- **Operator Options:** Remote receiver and transmitters, photo safety beams, leading edge switch.
- **Accessories:** Industry standard accessories can be added such as motion sensors, loop detectors, ceiling pull switches, lock-out switches, other various types of switches, and door status / movement indicators such as lights and buzzers.
- **Windows:** 32" high with width varying by width of door panel.
- **Fabric & Fabric Colors:** Frost, white, black, blue, red yellow, silver, tan, green, anti-static, and insect screen.

NOTE: Certain options may only be available with specific operators. **Refer to Section 39.5, RS-500/600 Door Options and Accessories.**

5 Differences between a RS-500 and RS-600 Series Door

	<u>RS-500 Series</u>	<u>RS-600 Series</u>
Speed (Brother Motor Option)	Up to 18" Per Sec	Up to 48" Per Sec
Speed (Manaras Motor)	@8-11" Per Sec	@16-22" Per Sec
Motor (Brother)	1/4hp	1/2hp
Motor (Manaras)	1/2hp GH	1hp GH
Drive Pipe	2 ½ inches	6 inches
Head Unit	Small	Large
*Standard Controller Input Voltage (Brother Motor Option)	115VAC	230VAC

***NOTE: When Brother Motor Option is used you can request that a RS-500 Door be wired for 115VAC or 230VAC. The RS-600 is wired for 230 VAC only. This must be done prior to purchase to ensure the door has the correct brake rectifier installed.**

6 Operator Options



NSF Certified Doors are equipped with Left mount Brother operators, Smart Controller, and Magnetic Track Sealing System

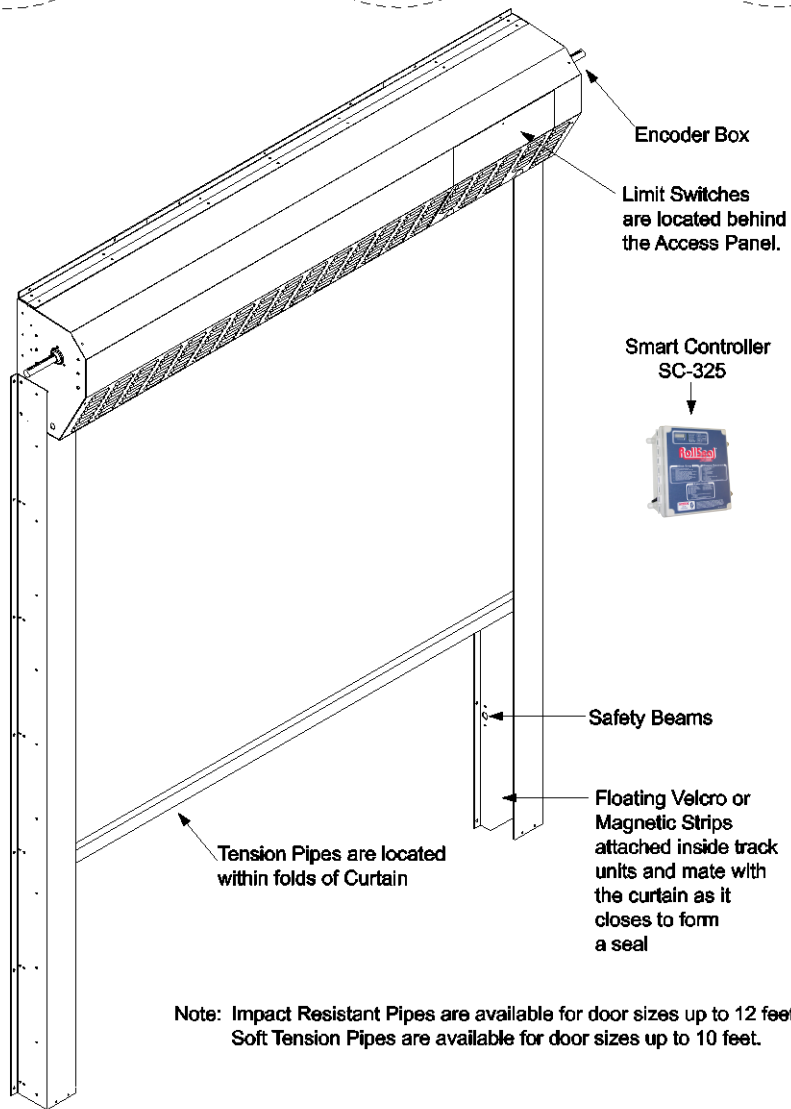
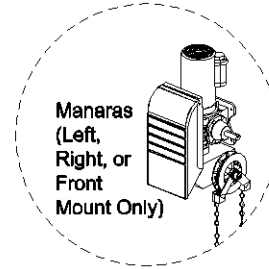
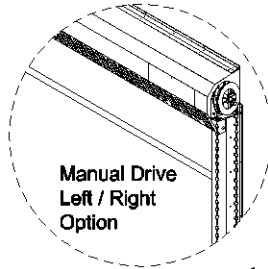
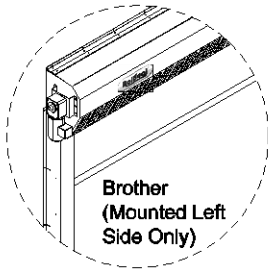

7 Ratings and Specifications RS-500/600 Series (Brother Motor)



NSF Certified Doors are equipped with Left mount Brother operators, Smart Controller, and Magnetic Track Sealing System

RS-500 Doors					
Part Number	6607-8057	6607-8056	6607-8058	6607-8060	6607-8061
Model Number	SC-325-V01-115	SC-325-V02-0	SC-325-V01-115-W01	SC-325-V01-115-PLUS	SC-325-V01-230-PLUS
Power Supply	115 VAC 50/60 Hz Single Phase is <u>Factory Pre-Set</u> 230 VAC 50/60 Hz Single Phase see <u>RollSeal SC-325 & SC-650 Controllers Owner's Manual</u> Section 12-12.1 Diagram 12A			115 VAC or 230 VAC 50/60 Hz Single Phase	230 VAC 50/60 Hz Single Phase
Temperature Range	32°F - 115°F (0°C - 46°C)				
Inputs	10 Amps @ 115 VAC Single Phase or 6 Amps @ 230 VAC Single Phase			10 Amps @ 115 VAC Single Phase	6 Amps @ 230 VAC Single Phase
Outputs	230 VAC Three Phase 1/4 H.P.				
Drive Setting	Version 01	Version 02	Version 01	Version 01	Version 01
Factory Preset Voltage Switch & Jumper	115 VAC				230 VAC
Switch & Warning Wires with Conduit	N/A		Switch Wiring Option		

Optional Condensation Management System
<p>CONDENSATION MANAGEMENT SYSTEM (CMS): Voltage Rating 230 VAC ± 10% 50/60 Hz 1-PH Blower 135 Watt Heater 1200 Watt Total Current: 6.0 A @ 230 VAC (Typical) 9.0 A @ 230 VAC (Max.)</p> 

RS-600 Doors				
Part Number	6607-8100	6607-8101	6607-8102	6607-8103
Model Number	SC-650-V01-0	SC-650-V02-0	SC-650-V01-W01-PLUS	SC-650-V02-W01-PLUS
Power Supply	230 VAC 50/60 Hz Single Phase			
Temperature Range	32°F - 115°F (0°C - 46°C)			
Inputs	8 Amps @ 230 VAC Single Phase			
Outputs	230 VAC Three Phase 1/2 H.P.			
Drive Setting	Version 01	Version 02	Version 01	Version 02
Factory Preset Voltage Switch & Jumper	230 VAC			
Switch & Warning Wires with Conduit	N/A		Switch Wiring Option	

8 RS-500 Series Door (Brother Motor)

See Section 7 for Ratings and Specifications.
Motor must be connected through Controller.



NSF Certified Doors are equipped with Left mount Brother operators, Smart Controller, and Magnetic Track Sealing System

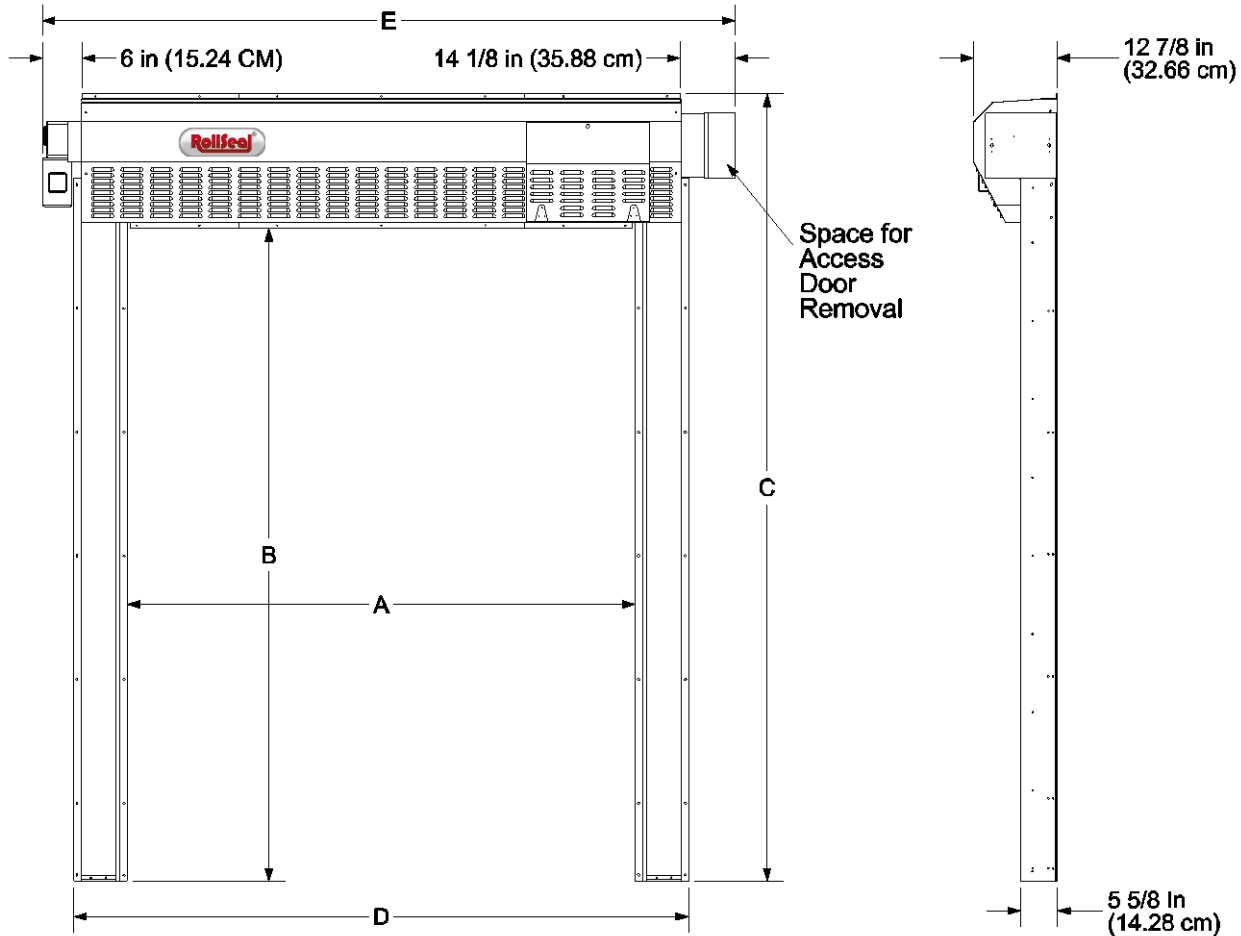

TABLE 1 RS-500 Door Standard Dimensions:

WIDTH Related Dimensions

RS-500 Door Width	A		D		E	
	In.	cm	In.	cm	In.	cm
4' (W)	48	122	64 3/8	164	82 5/16	209
5' (W)	60	152	76 3/8	194	94 5/16	240
6' (W)	72	183	88 3/8	225	106 5/16	270
6' 6" (W)	78	198	94 3/8	240	112 5/16	286
7' (W)	84	213	100 3/8	255	118 5/16	301
8' (W)	96	244	112 3/8	285	130 5/16	331
9' (W)	108	274	124 3/8	316	142 5/16	362
10' (W)	120	305	136 3/8	346	154 5/16	392
11' (W)	132	335	148 3/8	377	166 5/16	423
12' (W)	144	366	160 3/8	407	178 5/16	453

HEIGHT Related Dimensions

RS-500 Door Height	B		C	
	In.	cm	In.	cm
7' (H)	84	213	104 11/16	266
7' 6" (H)	90	229	110 11/16	281
8' (H)	96	244	116 11/16	296
9' (H)	108	274	128 11/16	327
10' (H)	120	305	140 11/16	357
11' (H)	132	335	152 11/16	388
12' (H)	144	366	164 11/16	418

9 RS-600 Series Door (Brother Motor)

See Section 7 for Ratings and Specifications.
Motor must be connected through Controller.



NSF Certified Doors are equipped with Left mount Brother operators, Smart Controller, and Magnetic Track Sealing System

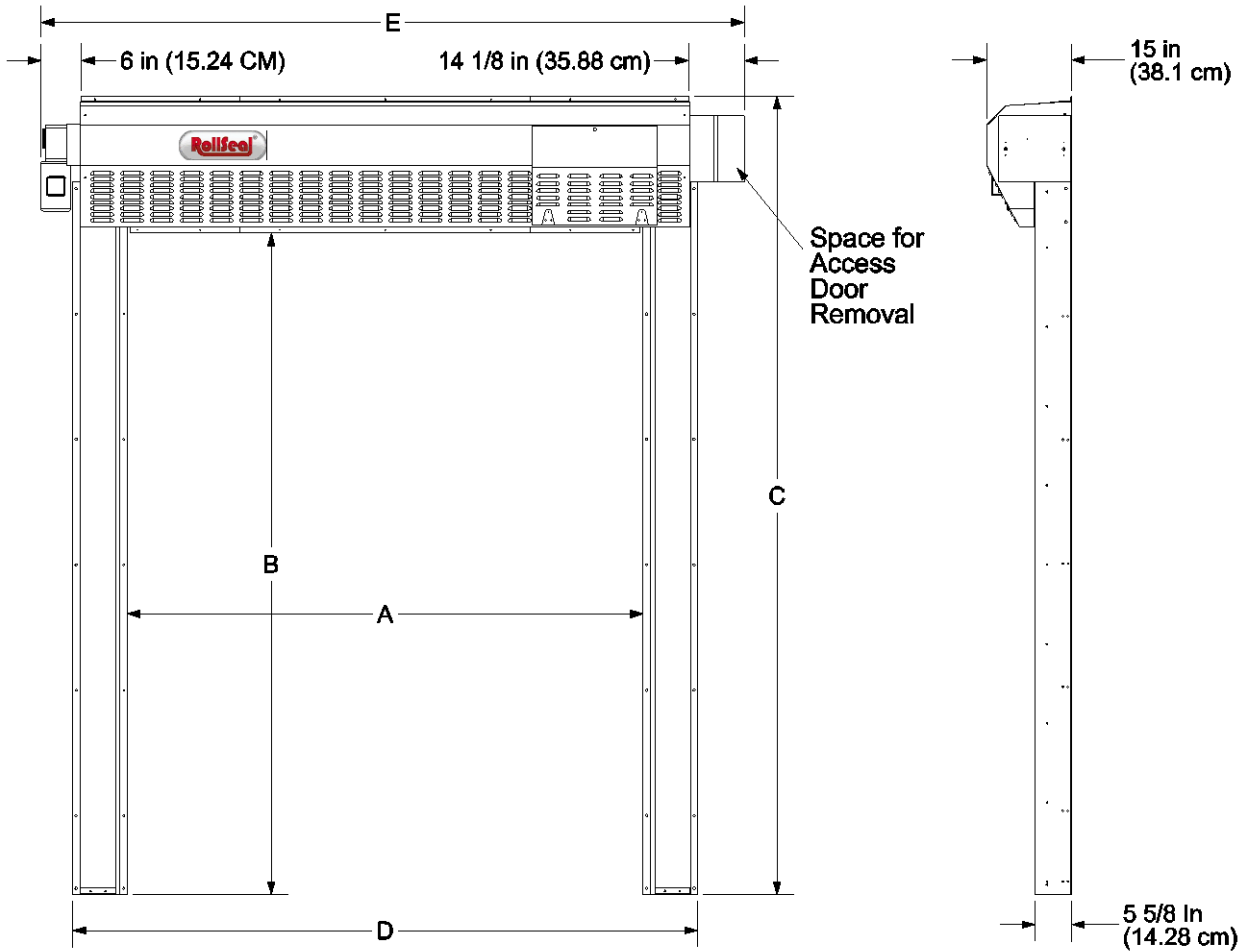

TABLE 2 RS-600 Door Standard Dimensions:

WIDTH Related Dimensions

RS-600 Door Width	A		D		E	
	In.	cm	In.	cm	In.	cm
4' (W)	48	122	64 3/8	164	82 5/16	209
5' (W)	60	152	76 3/8	194	94 5/16	240
6' (W)	72	183	88 3/8	225	106 5/16	270
6' 6" (W)	78	198	94 3/8	240	112 5/16	286
7' (W)	84	213	100 3/8	255	118 5/16	301
8' (W)	96	244	112 3/8	285	130 5/16	331
9' (W)	108	274	124 3/8	316	142 5/16	362
10' (W)	120	305	136 3/8	346	154 5/16	392
11' (W)	132	335	148 3/8	377	166 5/16	423
12' (W)	144	366	160 3/8	407	178 5/16	453

HEIGHT Related Dimensions

RS-600 Door Height	B		C	
	In.	cm	In.	cm
7' (H)	84	213	108	274
7' 6" (H)	90	229	114	290
8' (H)	96	244	120	305
9' (H)	108	274	132	335
10' (H)	120	305	144	366
11' (H)	132	335	156	396
12' (H)	144	366	168	427

10 RS-500 Series Door with Optional Condensation Management System



NSF Certified Doors are equipped with Left mount Brother operators, Smart Controller, and Magnetic Track Sealing System

See Section 7 for Ratings and Specifications.
Motor must be connected through Controller.

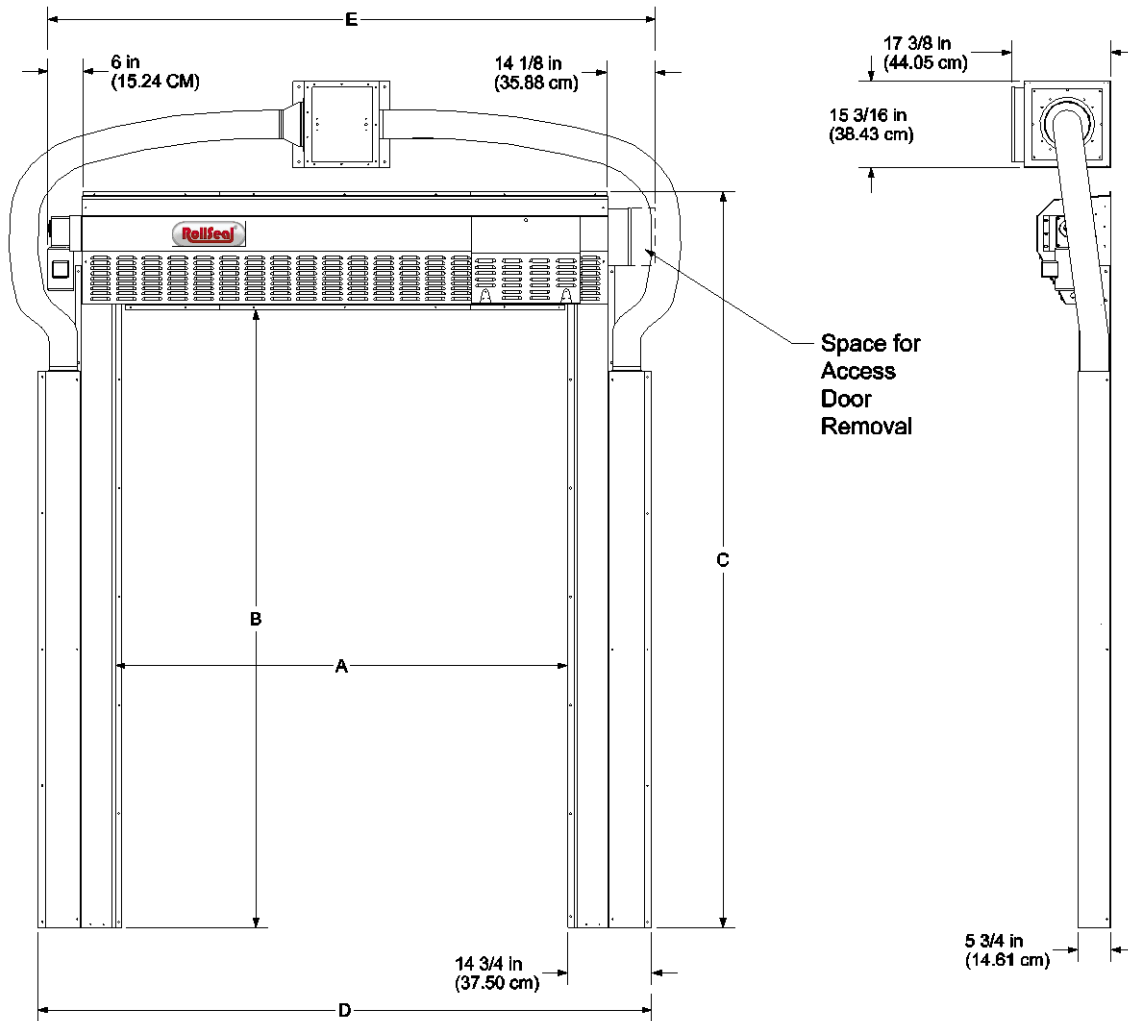

TABLE 3 RS-500 Door with Freezer Kit

WIDTH Related Dimensions

RS-600 Door Width	A		D		E	
	In.	cm	In.	Cm	In.	cm
4' (W)	48	122	77 1/2	197	82 7/16	209
5' (W)	60	152	89 1/2	227	94 7/16	240
6' (W)	72	183	101 1/2	258	106 7/16	270
6' 6" (W)	78	198	107 1/2	273	112 7/16	286
7' (W)	84	213	113 1/2	288	118 7/16	301
8' (W)	96	244	125 1/2	319	130 7/16	331
9' (W)	108	274	137 1/2	349	142 7/16	362
10' (W)	120	305	149 1/2	380	154 7/16	392
11' (W)	132	335	161 1/2	410	166 7/16	423
12' (W)	144	366	173 1/2	441	178 7/16	453

HEIGHT Related Dimensions

RS-600 Door Height	B		C	
	In.	cm	In.	cm
7' (H)	84	213	104 11/16	266
7' 6" (H)	90	229	110 11/16	281
8' (H)	96	244	116 11/16	296
9' (H)	108	274	128 11/16	327
10' (H)	120	305	140 11/16	357
11' (H)	132	335	152 11/16	388
12' (H)	144	366	164 11/16	418

11 RS-600 Series Door with Optional Condensation Management System



NSF Certified Doors are equipped with Left mount Brother operators, Smart Controller, and Magnetic Track Sealing System

See Section 7 for Ratings and Specifications.
Motor must be connected through Controller.

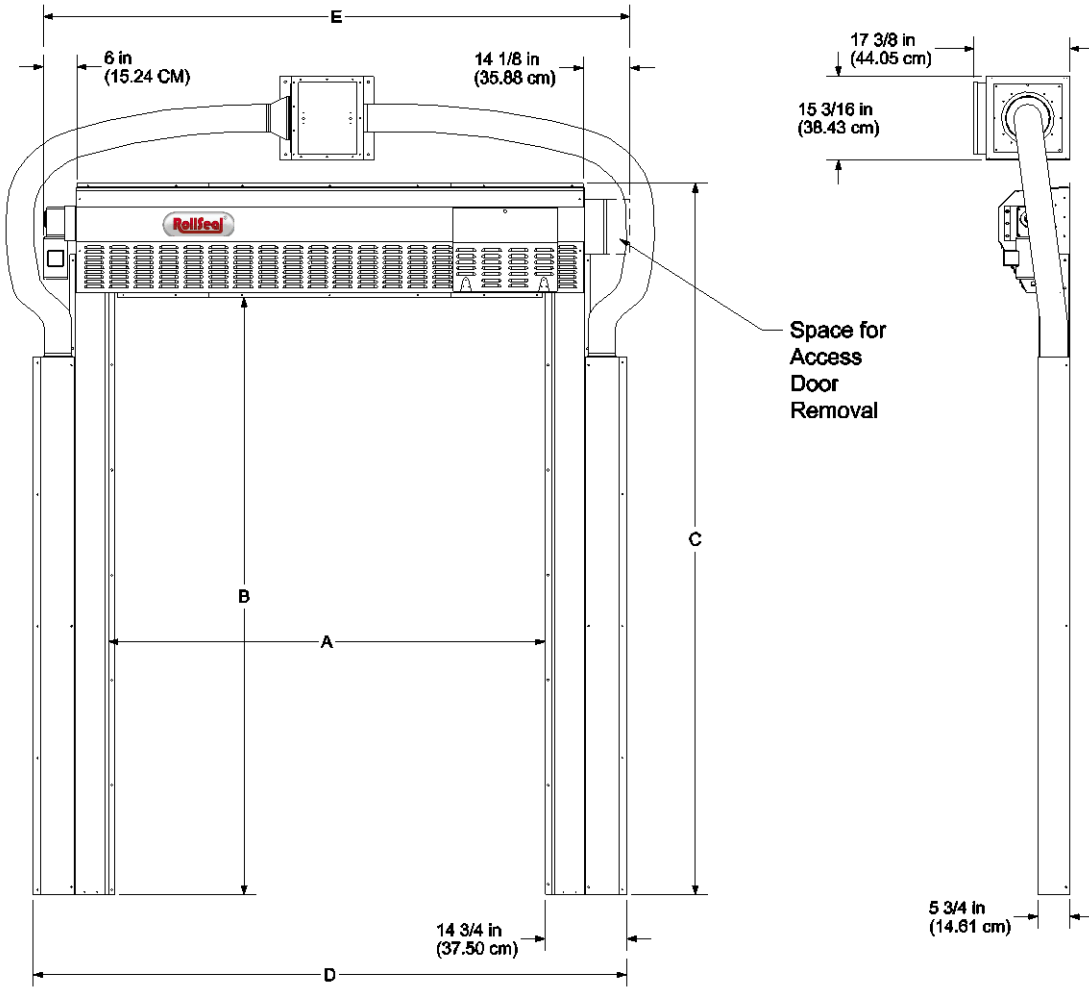

TABLE 4 RS-600 Door with Freezer Kit Dimensions:

WIDTH Related Dimensions

RS-600 Door Width	A		D		E	
	In.	cm	In.	Cm	In.	cm
4' (W)	48	122	77 1/2	197	82 7/16	209
5' (W)	60	152	89 1/2	227	94 7/16	240
6' (W)	72	183	101 1/2	258	106 7/16	270
6' 6" (W)	78	198	107 1/2	273	112 7/16	286
7' (W)	84	213	113 1/2	288	118 7/16	301
8' (W)	96	244	125 1/2	319	130 7/16	331
9' (W)	108	274	137 1/2	349	142 7/16	362
10' (W)	120	305	149 1/2	380	154 7/16	392
11' (W)	132	335	161 1/2	410	166 7/16	423
12' (W)	144	366	173 1/2	441	178 7/16	453

HEIGHT Related Dimensions

RS-600 Door Height	B		C	
	In.	cm	In.	cm
7' (H)	84	213	108	274
7' 6" (H)	90	229	114	290
8' (H)	96	244	120	305
9' (H)	108	274	132	335
10' (H)	120	305	144	366
11' (H)	132	335	156	396
12' (H)	144	366	168	427

12 Installation of RS-500/600 Series Doors

12.1 Tools Required

3/8 in. (10 mm) Power screwdriver (portable) 3/16 in. (5 mm) Drill bit and power drill 3/8 x 1 in. Bolts and nuts (supplied)	Socket Hammer Tape measure Carpenter's level
<i>NOTE: Other Tools May Be Required According To Installation.</i>	

12.2 Overview

The RS-500/600 Series doors are shipped with pre-assembled vertical members (left track and right track), and a pre-assembled horizontal member (head unit). When components are received, check for damaged, loose or missing parts. If there are damaged or missing parts contact your RollSeal distributor immediately. Please read and understand all instructions in this manual before beginning installation.

12.3 Adjusting the Door Framing or Clear Opening

Locate your particular system in the appropriate **Tables 1-4 (Sections 0, 9, 10, and 11)**. Read the value of height and width of the clear opening for the door size that you are installing. This gives the required dimensions of the clear opening. If necessary, adjust the dimensions of the mounting posts or framing members to the height and width of your RS-500/600 series door system as shown. Refer to **Section 12.4, Page 19, Diagram 12A** for details of attaching door to framing members. Framing material must provide suitable support for attachment of screws. Make sure that mounting posts or framing members are positioned so that the screw holes of the outer flanges of the vertical members will align with the mounting posts or framing members (**Section 12.4, Page 19, Diagram 12A**).

NOTE: Make sure that there is space for appropriate motor, control box or Condensation Management System (CMS) and freezer tracks (Freezer door option only) without encountering any obstructions during installation. Refer to appropriate cut sheet (Sections 0, 9, 10, and 11), and view the appropriate drawing of the door and operator to ensure required footprint.

NOTE: Allow 1' (30.4 cm) minimum, preferably 18" (45.7 cm) clearance above the Head Unit for future panel maintenance or replacement.

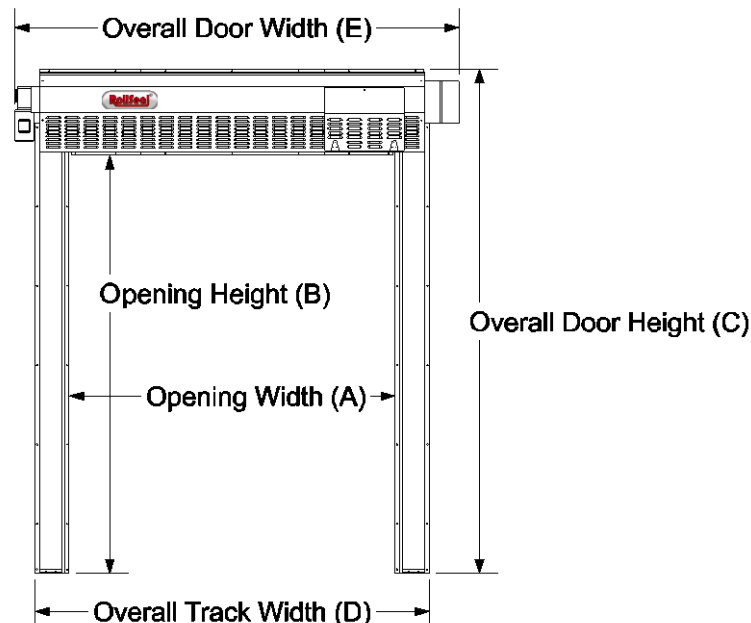

12.4 Attachment Points of Door

When sizing the clear opening for attachment of the door, pay close attention to the following guidelines. Door flanges have pre-drilled holes that serve as mounting points of door.

Flange widths are shown in **Diagram 12A**.

1. Make sure that door assembly is plumb & square.
2. The top unit has a top flange and a bottom flange. Make sure these flanges overlap framing.
3. The vertical members have inner flanges and outer flanges. The inner and outer flanges have pre-drilled holes that serve as attachment points. Make sure the outer flanges overlap framing.
4. When door is raised in front of clear opening (**Section 12.8, Page 22**), Diagram flanges must be flush against framing for attachment of screws.

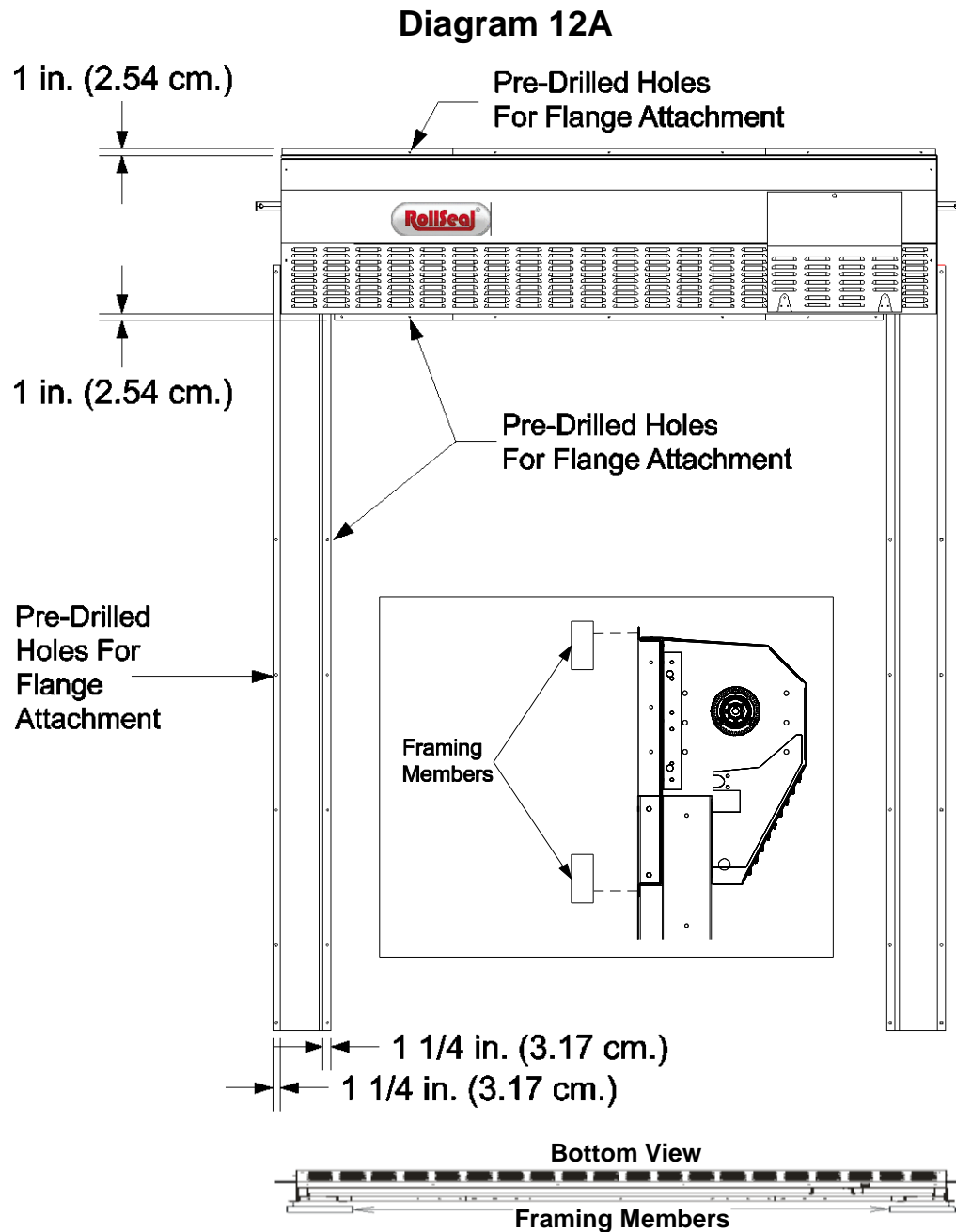

12.5 Assembly of Tracks

Taller doors that require a total track length over 13' have spliced tracks. If track sections need to be assembled, follow the instructions shown below.

1. Arrange the Top and Bottom Tracks so that they can be assembled. **See Diagram 12B.**
2. Slide the Bottom Track into the Top Track so that the Tracks butt together on the Splice Bracket and Splice Plate. **See Diagram 12C.**
3. Note that the Tracks butt together inside the Track Bracket and butt together on top of the Track Plate.
4. Bolt the Tracks together. Check that ALL bolts in the Splice Bracket and Splice Plate are properly tightened.

Diagram 12B

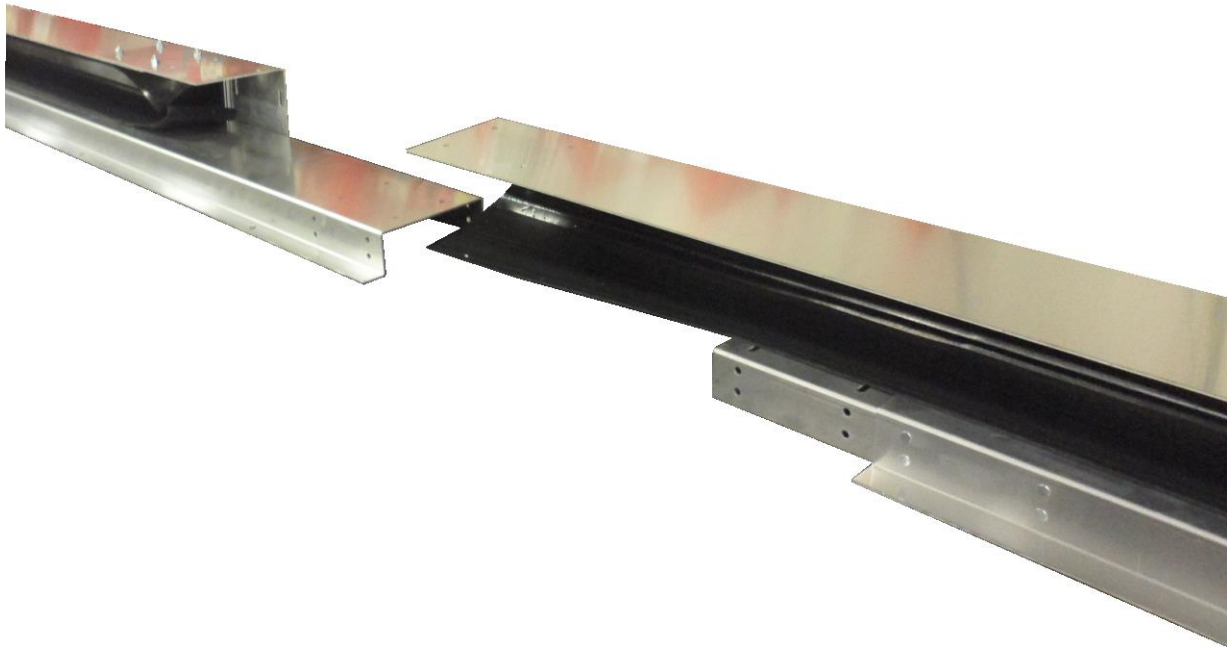
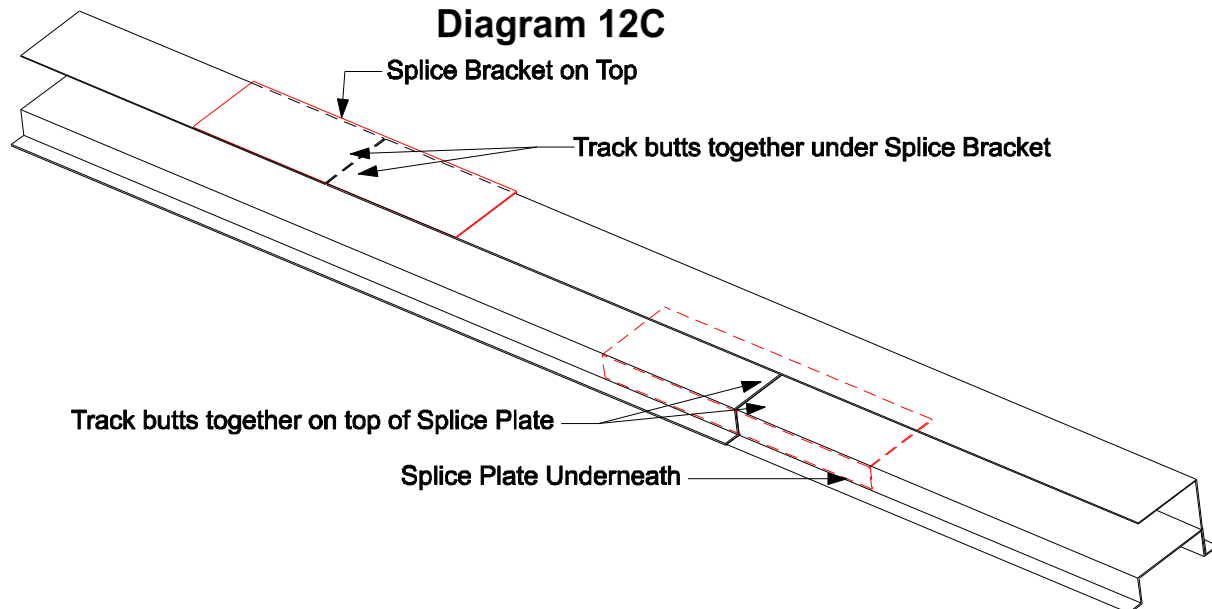

Diagram 12C



12.6 Assembly of Tracks to the Head Unit

Arrange the horizontal member, left vertical member (left track), and right vertical member (right track) on the floor in front of the clear opening as shown in **Diagram 12D**. The curtain side of the horizontal member and each vertical member faces down.

Diagram 12D

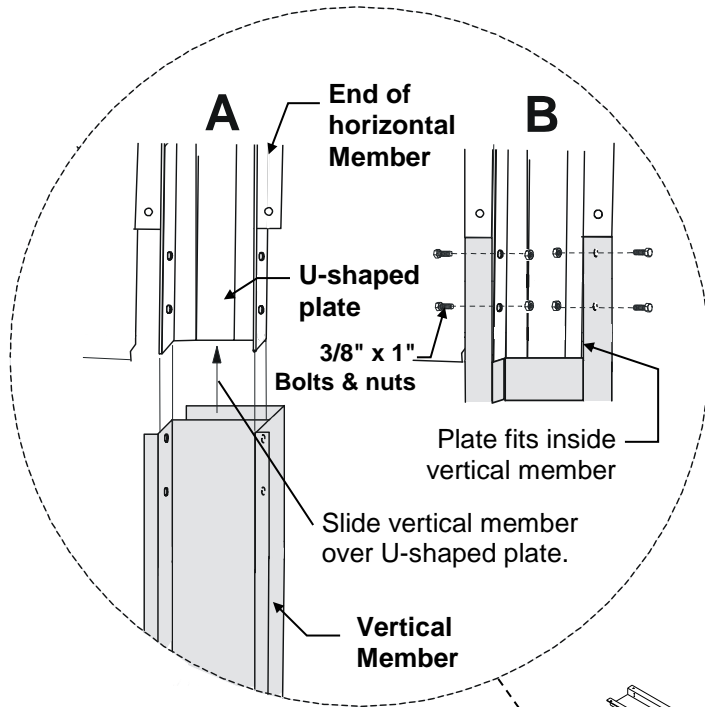

On each end of the horizontal member is a U-shaped plate that fits inside each vertical member. The U-shaped plate has four bolt holes, two on the inside and two on the outside flanges that match bolt holes in the vertical member. See diagram at left.

1. Align the vertical member with the U-shaped metal plate at end of horizontal member.
2. Slide the vertical member onto the outside of the U-shaped metal plate of the horizontal member as shown in A.
3. Insert bolts through bolt holes as shown in B. Install nuts. Tighten bolts & nuts securely.

Clear Opening
At this end of members

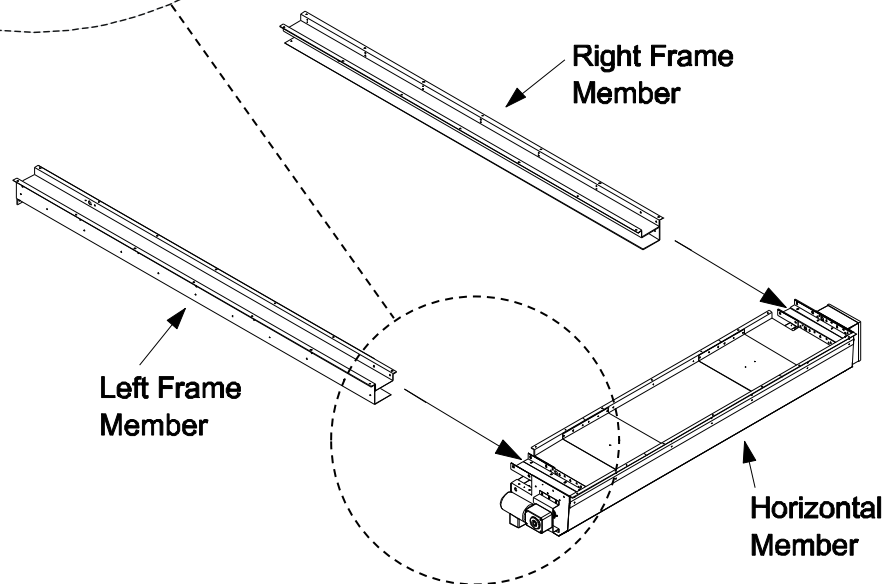

Placement of Parts for Assembly

Lay left track, right track, and horizontal member face down in front of the clear opening as shown.

12.7 Infrared Sensor Connectors (Brother Motor Option Only)

Located at the bottom of each vertical member is an infrared detector. The detector on each vertical member operates as a safety device if the infrared beam is interrupted. Door can be set to stop if beams are broken while closing or to stop and reverse to the full open position. Refer to the RollSeal SC-325 and SC-650 Controller Manual for more information.

1. Locate female connector on vertical member. This connector is attached to the infrared detector.
2. Locate male connector on horizontal member. Unroll cable until connectors meet. **Pull enough slack to create a service loop, such that connectors can be pulled out of tracks for photo eye replacement and troubleshooting purposes.**
3. Plug connectors together. Make sure connectors interlock.
4. Repeat for both infrared detectors.
5. Cable ties and adhesive mounts are supplied to secure wire to the inside of tracks.

NOTE: For each vertical member, unroll respective sensor cable attached to horizontal member until cable reaches the sensor connector attached to the vertical member.

NOTE: Pull Enough Slack To Leave A Service Loop For Photo Eye Replacement And Troubleshooting Purposes

Diagram 12E

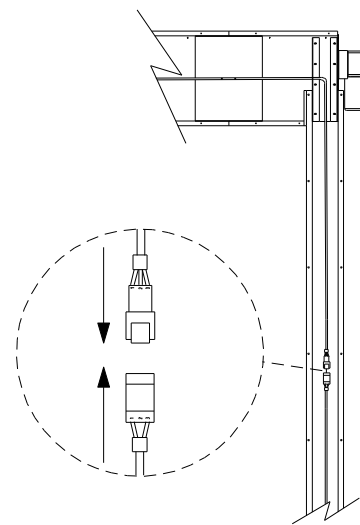

12.8 Fastening Door Assembly to Clear Opening

Diagram 12F

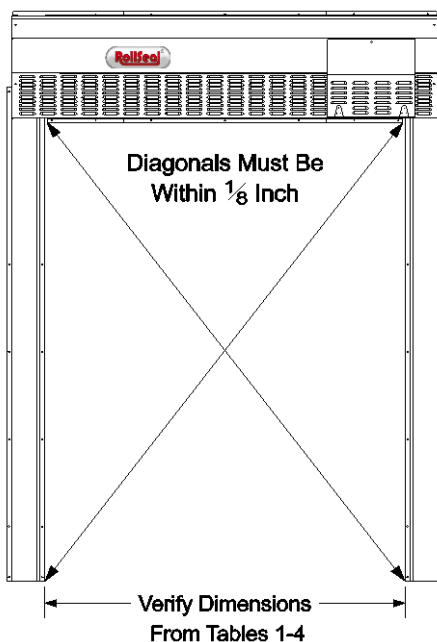

1. Use a tape measure and make sure that the overall height and overall width of the clear opening meet the door requirements. Reference appropriate Table 1-4, Sections 0, 9, 10, and 11.
2. Make sure that door assembly is plumb & square. **See Diagram 12F.**
3. Center door assembly on clear opening. Align the bottom of each vertical member with the respective framing board or posts of the clear opening.

Diagram 12G

NOTE: The vertical members should be aligned so that their outer flanges will exactly overlap with the framing boards or posts when the door assembly is raised into position.

4. Assemble workers and equipment into position on each side of the door assembly.

IMPORTANT: SLOWLY LIFT TOP OF DOOR ASSEMBLY TO RAISE THE DOOR. See Diagram 12G.

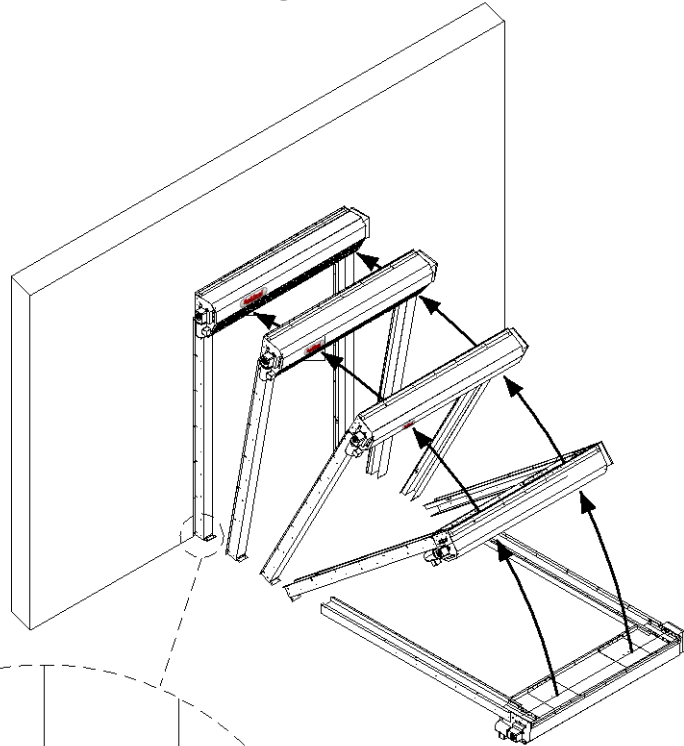
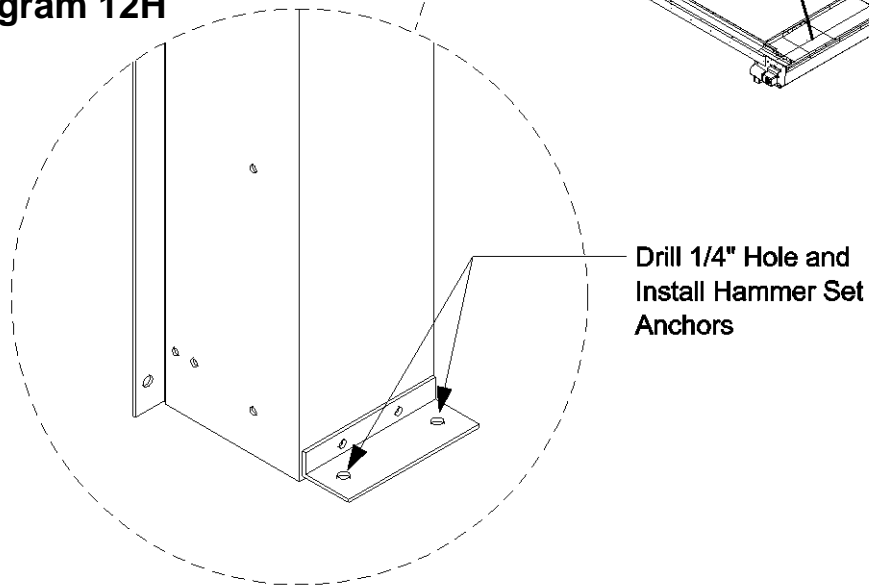

Diagram 12H



5. Lean door assembly upright against clear opening.
6. Carefully press flanges of the door assembly flush against faces of framing boards or posts.
7. Fasten Tek screws (in steel) or lag screws (in wood) through the flanges on sides of door assembly. Securely tighten all screws.
8. On the lower and upper flanges of the horizontal member there are attachment points for fastening screws. Fasten Tek screws (in steel) or lag screws (in wood) through the holes. This secures the top of the door to the clear opening.
9. Locate the two floor mounting holes at the bottom of the left and right tracks. **See Diagram 12H.**
10. Drill a 1/4" hole and install Hammer Set Anchors (1002-6030) in both right and left tracks. See Diagram 12H.
11. This completes fastening of the door assembly to the clear opening.

13 Manaras Motor Mounting to RS-500/600 Series Doors

Warning!

Prior to mounting the Manaras it is important that you read all the information contained within this document and the Manaras Installation and Instruction Manual provided with the door. Failure to do so could result in severe personnel injury or damage to equipment!

For more detailed information on mounting, wiring and operating the Manaras, refer to the Manaras Installation and Instruction Manual provided with the door.

Sprockets are mounted as follows on RS-500/600 Series Doors:

- RS500: 50-23 (motor) & 50-12 (door)
- RS600: 50-12 (motor) & 50-23 (door)
- Optional: 50-12 (motor & door) [Special Order]

- RS-500 Series Motor Rating 1/2 HP
 - 115V Single Phase 8.6 amp
 - 230V Single Phase 4.1 amp
 - 208V 3 Phase 3.4 amp
 - 460V 3 Phase 1.7 amp

- RS-600 Series Motor Rating 1 HP (if the door is more than 13 feet wide)
 - 115V Single Phase 13.4 amp
 - 230V Single Phase 6.7 amp
 - 208V 3 Phase 3.4 amp

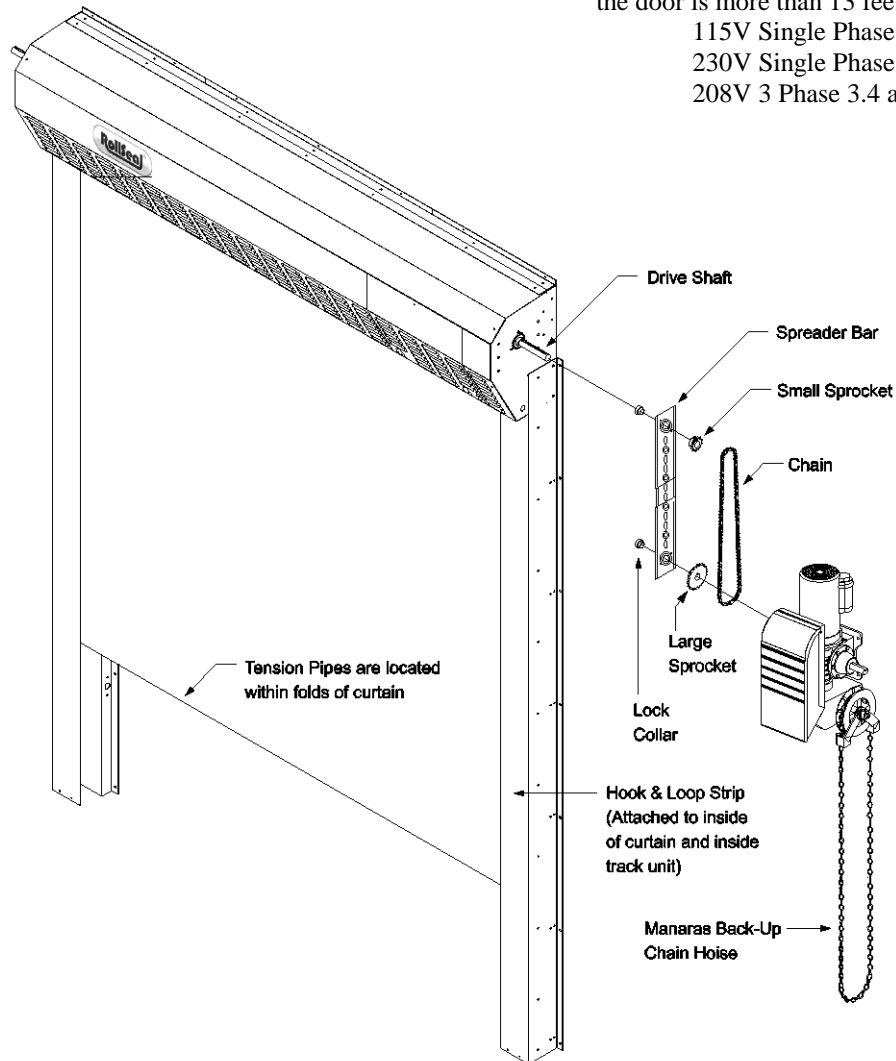

NOTE: Manaras GH Operator can be mounted in its normal upright position for all options. However it may be necessary to remove and re-install the chain and pulley on the opposite side to prevent chain interference. Refer to Manaras Opera GH Installation & Instruction Manual if your operator is a gear head operator.

Manaras Motor Mounting Configurations:

There are a variety of ways that a Manaras Motor can be mounted to the RollSeal Door. As shown below, we provide a variety of brackets that can be used to mount the motor in the area that is desired. The positions listed below are the standard mounting configurations but they can be altered to some degree if needed.

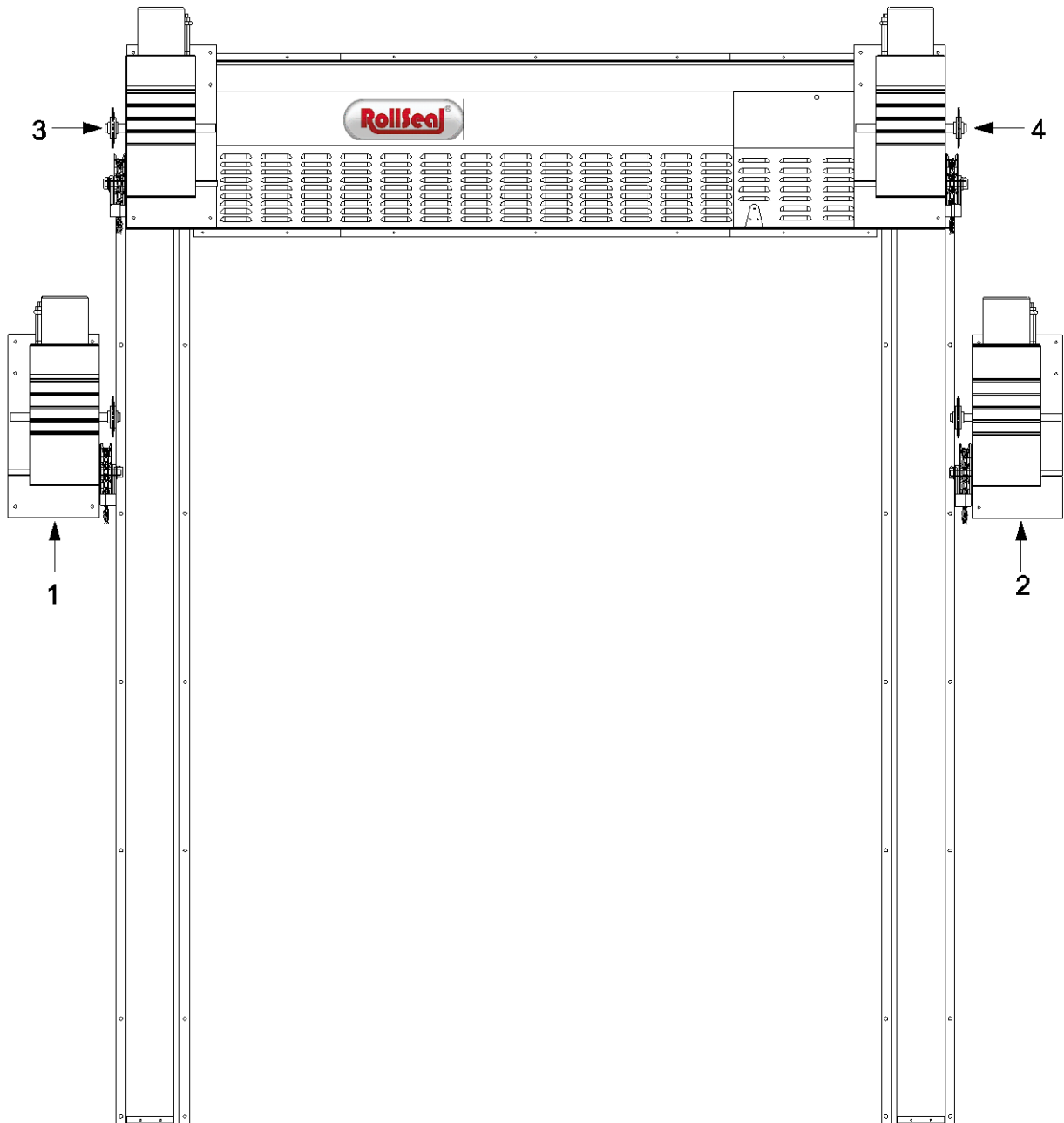

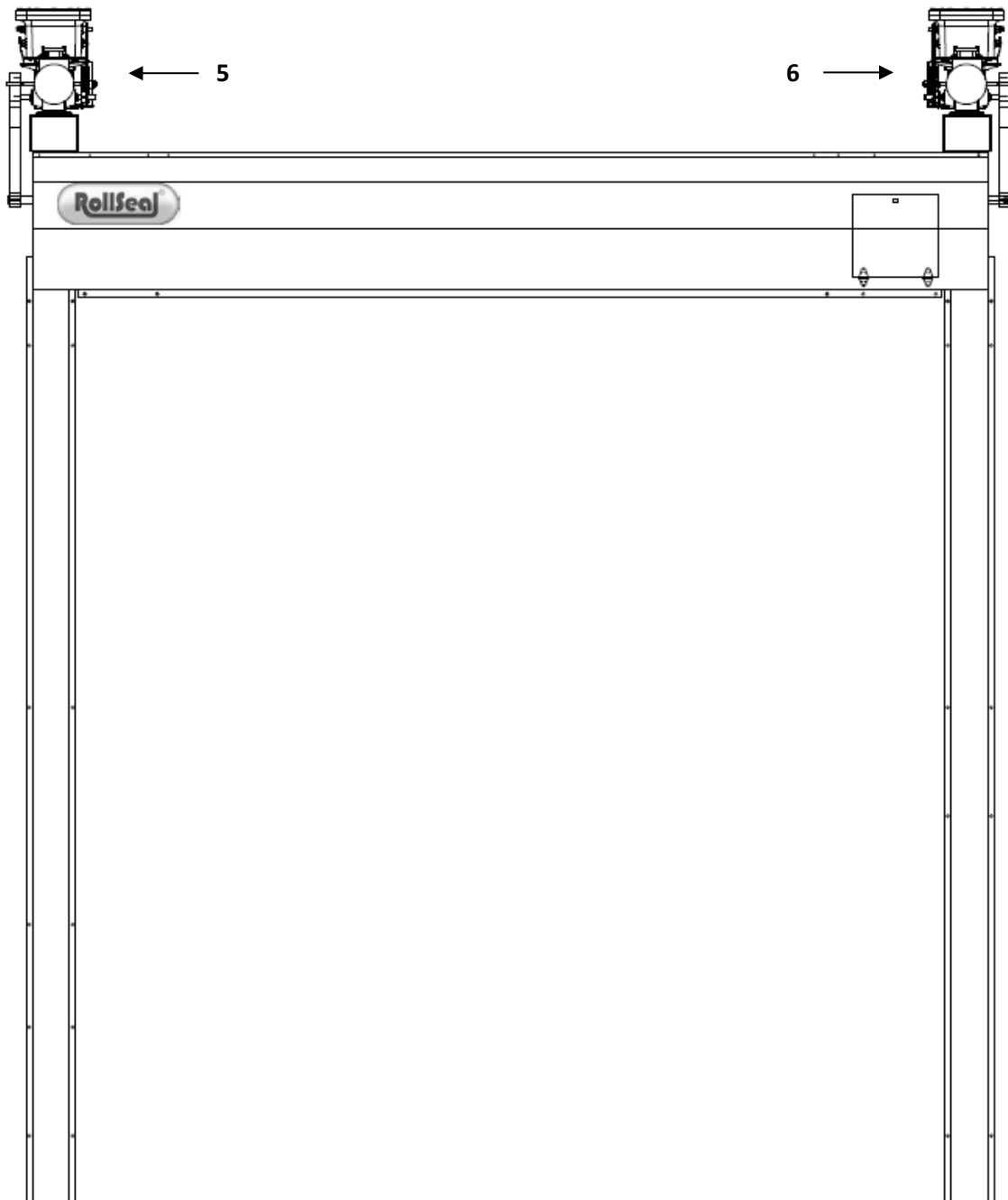

POSITION 1 – GH motor mounted on the left side.

Parts Required – Wall Mount Bracket (6450-0907), normal size spreader bar, normal size chain, 2 collars and 2 sprockets. (1 size 50-12 and 1 50-23)

POSITION 2 – GH motor mounted on the right side.

Parts Required – Wall Mount Bracket (6450-0907), normal size spreader bar, normal size chain, 2 collars and 2 sprockets. (1 size 50-12 and 1 50-23)

POSITION 3 – GH motor mounted on the left side.

Parts Required – Front Mount Bracket (6421-6543 {D5} or 6421-6542 {D6}), normal size spreader bar, normal size chain, 2 collars and 2 sprockets. (1 size 50-12 and 1 50-23)

POSITION 4 – GH motor mounted on the right side.

Parts Required – Front Mount Bracket (6421-6543 {D5} or 6421-6542 {D6}), normal size spreader bar, normal size chain, 2 collars and 2 sprockets. (1 size 50-12 and 1 50-23)

POSITION 5 – GH motor mounted on the left side.

Parts Required – Overhead Booth Mount Bracket (6450-0906), normal size spreader bar, normal size chain, 2 collars and 2 sprockets. (1 size 50-12 and 1 50-23)

POSITION 6 – GH motor mounted on the right side.

Parts Required – Overhead Booth Mount Bracket (6450-0906), normal size spreader bar, normal size chain, 2 collars and 2 sprockets. (1 size 50-12 and 1 50-23)

As shown above, there are six standard mounting positions for the Manaras Motor. These six mounting positions require the use of one of the three mounting brackets which can be used on the left or right hand side of the door. In order to better understand the three Manaras Mounting Brackets, they are detailed below to include installation instructions.

WARNING: Due to the uncertainty of the mounting surface and booth construction, the installation technician is responsible to ensure that the bracket is secured in a safe manner. There may be a scenario where bracing has to be added to stiffen the booth in the mounting location.

Wall Mount Bracket: (Position 1 & 2)

1. Position the Manaras Wall Mount Bracket (0404-14293), to the wall of the booth in the required location. The installation technicians are responsible for providing the correct mounting hardware from the below information to ensure a secure constraint.
 - a. Before mounting the bracket, ensure that the Manaras Motor Output Shaft and the Door Shaft are in the correct position in respect to each other.
 - b. Due to the nature of the loading configuration, there is a substantial tensile and shear load on the fasteners that connect the mounting bracket to the wall.
 - c. Due to the magnitude of the load and the uncertainty in the vibratory load, HHT does not provide a definite mounting solution that will work with all booths. Below are three mounting configurations that have been used in the past that have worked depending on the structure of the booth.
 - 1). Ideally HHT recommends mounting to structural support bracing if present with 3/8" hex head bolts (not provided).
 - 2). If no support bracing is present in the top of the booth, HHT recommends through bolting the bracket with 3/8" thru-bolts (not provided).
 - 3). In the case that neither of the previously mentioned mounting scenarios are possible, assuming that the wall material is 18 gauge or greater, HHT recommends using the six (6) provided Fab-Loks to secure the bracket to the wall of the booth.
 - d. Configuration 1 and 2 are optimal due to the uncertainty in the vibratory load. Configuration 3 may allow vibration during operation. The installation technician is responsible to ensure that there is not excess vibration during operation.
2. Once the Motor Mount Bracket is mounted and secured as described, mount the motor to the bracket with the provided 3/8" bolts (4). Place a washer between the nut and the inside of the bracket slot and hand tighten the motor mount hardware in the slotted holes.
3. The motor will have to be adjusted depending on the mounting position as described in MANARAS Installation and Instruction Manual.
4. Once the motor is in the correct mounting position, tighten the hardware with the required 9/16" wrenches.

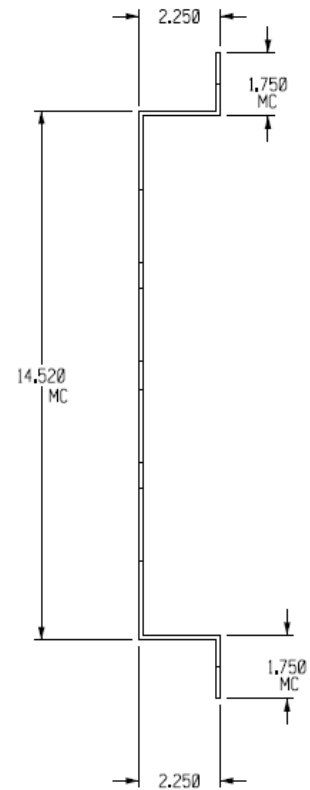
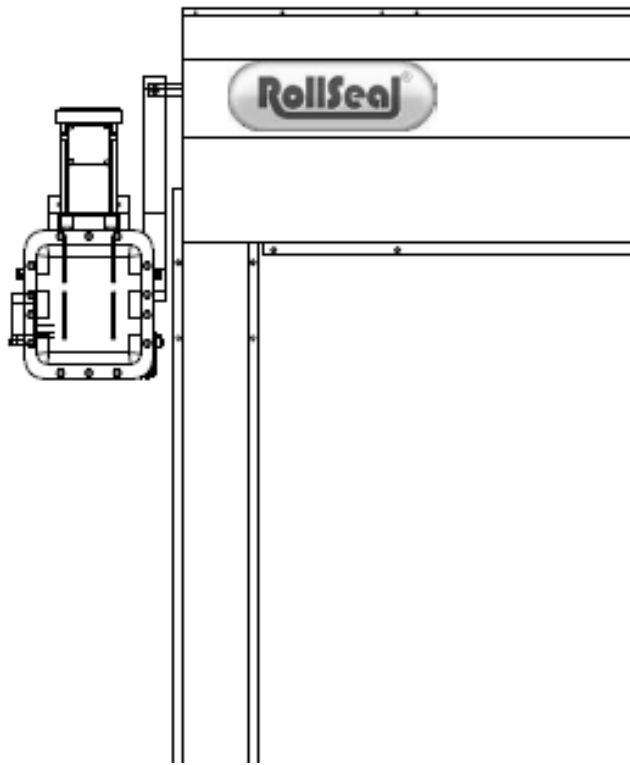

Front Mount Bracket: (Position 3 & 4)

1. The Manaras Front Mount Bracket is preinstalled prior to shipment. HHT recommends that all the bracket assembly fasteners be checked to ensure nothing has vibrated loose during transport.
2. Once the Door is installed and all the fasteners have been secured, the motor can be mounted to the front mount bracket.
3. There will be four (4) 3/8" hex head bolts provided with the front mount bracket and will be hand tightened in the motor mounting slots shown in Figure 1 on the front of the bracket for shipping purposes.
4. Remove these four (4) bolts and lift the motor into place. Once the motor is aligned, insert the 3/8" bolts through the motor mount base and into the slots on the front of the bracket. Place the provided washers and lock nuts on the inside of the bracket and tighten until the nuts are snug with the required 9/16" wrench.
5. The motor will have to be adjusted depending on the mounting position as described in MANARAS Installation and Instruction Manual.
6. Once the motor is in the correct mounting position, and the chain and spreader bar are set correctly, tighten the motor mount hardware.
7. The figure below shows how the Manaras Motor should look once it is fully installed.

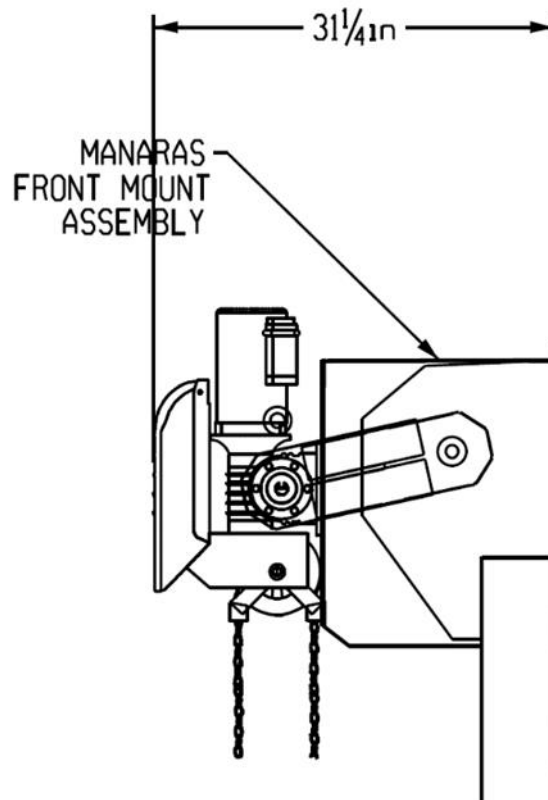

Overhead Booth Mount Bracket: (Position 5 & 6)

1. Position the Manaras Motor Mount Bottom Bracket (0404-14299) to the top of the booth in the required location. The installation technicians are responsible for providing the correct mounting hardware from the below information to ensure a secure constraint.
 - a. In order to keep the Manaras Motor Output Shaft and the Door Shaft in the correct position in respect to each other, the mounting bracket may need to be slid over the edge of the booth as shown in the below figures.
 - b. Due to the nature of the loading configuration, HHT does not recommend sliding the bracket over the edge of the booth more than eight (8) inches. This is due to the uncertainty of the mounting surface.
 - c. With the previously described mounting position, there is a substantial tensile load placed on the mounting fasteners. Due to the magnitude of the load and the uncertainty in the vibratory load, HHT does not provide a definite mounting solution that will work with all booths. Below are three mounting configurations that have been used in the past that have worked depending on the structure on the booth.
 - 1). Ideally HHT recommends mounting to structural support bracing if present with 3/8" hex head bolts (not provided).
 - 2). If no support bracing is present in the top of the booth, HHT recommends through bolting the bracket with 3/8" thru-bolts (not provided).
 - 3). In the case that neither of the previously mentioned mounting scenarios are possible, assuming that the roof material is 18 gauge or greater, HHT recommends using the six (6) provided Fab-Loks to secure the bracket to the top of the booth.
 - d. Configuration 1 and 2 are optimal due to the uncertainty in the vibratory load. Configuration 3 may allow vibration during operation. The installation technician is responsible to ensure that there is not excess vibration during operation.

2. Once the Motor Mount Bottom Bracket is secured, slide the Motor Mount Upper Bracket (0404-14294) into place as shown in the below figures.
3. Insert the provided 1/4" bolts (10) with washers on each side into the holes to connect the Top and Bottom Brackets.
4. Hand tighten the provided nuts on the bolts that were installed in step 3 and ensure that the top bracket is aligned correctly.
5. Using the required 7/16" wrenches, tighten the hardware.
6. Once the Motor Mount Bracket is assembled and tightened as described, mount the motor to the top of the bracket with the provided 3/8" bolts (4). Place a washer between the nut and the inside of the bracket slot and hand tighten the motor mount hardware in the slotted holes.
7. The motor will have to be adjusted depending on the mounting position as described MANARAS Installation and Instruction Manual.
8. Once the motor is in the correct mounting position, tighten the hardware with the required 9/16" wrenches. Once installed, the mount should look similar to the figure below.

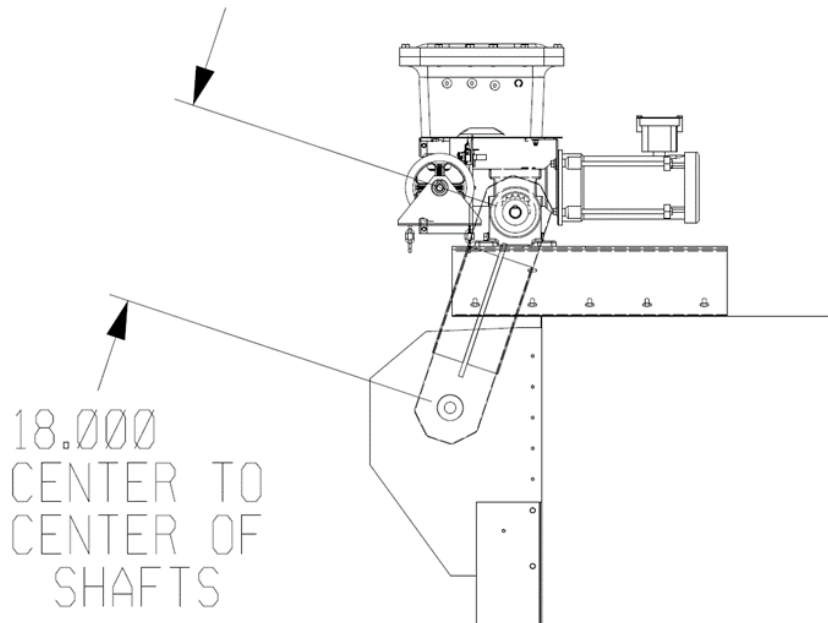
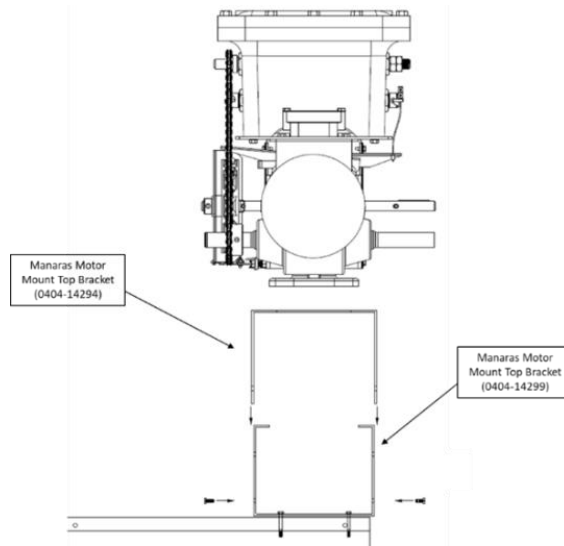

Spreader Bar Assembly

Diagram 13A

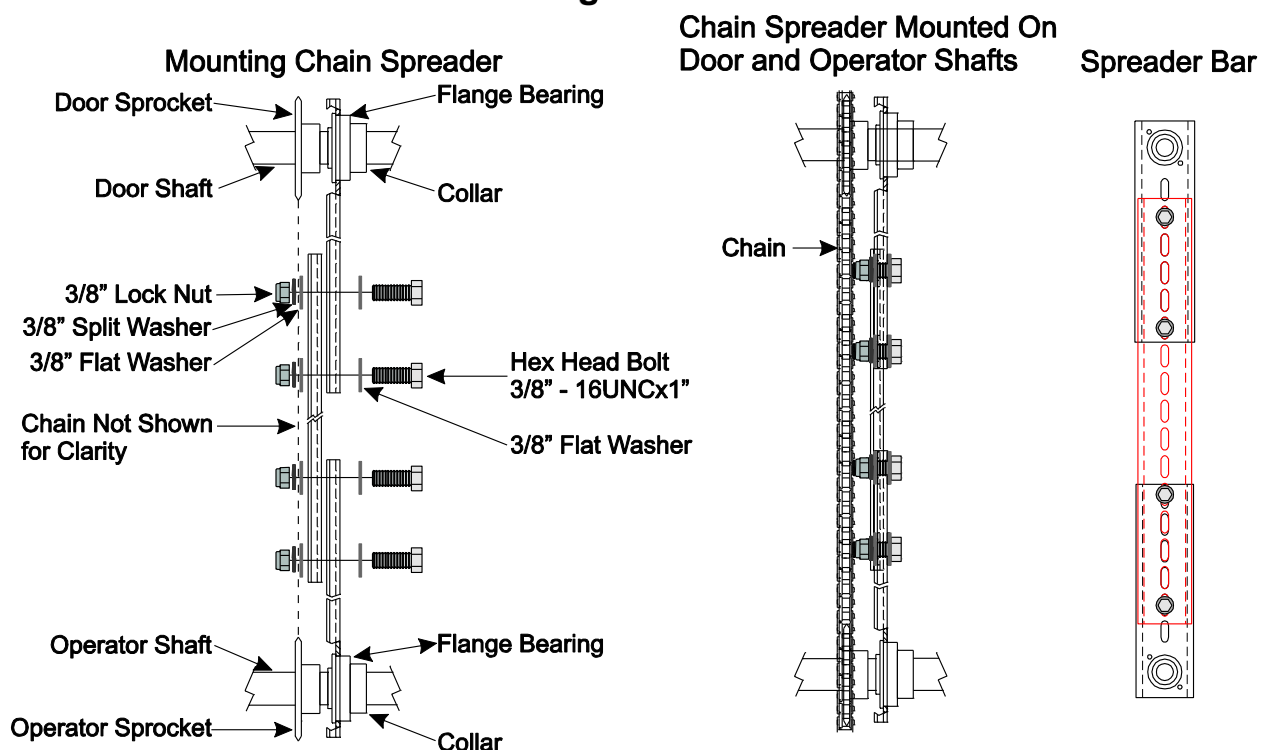

Length of Spreader Bar and chain may vary according to mounting option selected. For motors mounted more than 18" away, the Extended Chain and Spreader Bar must be used. (See Diagram 13A)

⚠ CAUTION!

Failure to arrange spreader bar, sprocket and collar parts in specific order could result in damage.

NOTE: If sprockets are greater than 18 inches apart you must have Extended Spreader Bar and Chain Kit (6450-7623). This will allow for up to 18 inches of adjustment.

14 Manaras Manual Operation

The RS-500/600 Door can be operated manually in the event of a power outage or if there is a motor malfunction. The automatic emergency chain hoist disconnect mechanism is provided in order to operate the door manually. A floor level disconnect is not required. In one simple step and by pulling the hand chain in the desired direction, the following operations may be successfully completed.

⚠ Warning!

Do not attempt to manually operate the door while the operator is running. Do not attempt to manually force a malfunctioning door to open or close. The chain is an emergency device and is not designed to operate a door with serious mechanical problems.

Warning!

NEVER RELEASE CHAIN! If Chain Is Released, Door Will Drop With Rapid Motion.

Injury May Occur If Chain Is Released!

Do not remove the cable tie securing the chain to the chain guide until after the chain bracket is completely installed and the chain is secure. Remove and discard the cable tie securing the chain to the chain guide prior to manual operation.

Diagram 14A Chain Hoist Disconnect Mechanism

Manual Mode

Pull chain on either side to operate door.

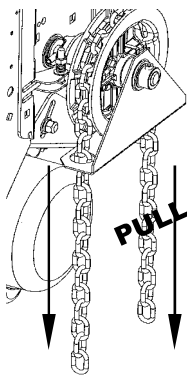

Return to Electric Mode

Wiggle chain until it moves freely.

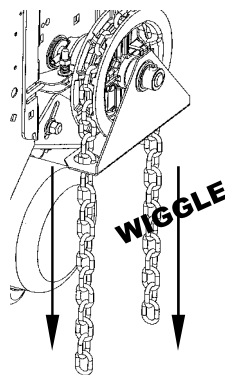

Storage

Follow the 3 steps shown below to attach the chain (when not in use) to the chain keeper.

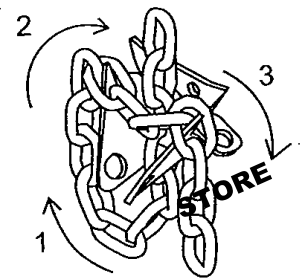

15 Manaras Motor Operation

Complete installation and operating instructions are provided with the Manaras Operator at the time of delivery. Refer to these instructions for the proper installation and alignment of the Manaras operator.

After the door has been secured to its frame (see **Section 12.8**), the Manaras motor has been mounted with chain, spreader bar and associated hardware (see **Section 13**), the door will be ready to operate after completing the following steps.

Warning!

To Avoid The Danger Of Possible Damage To The Door And Operator, Travelling Cams Must Be Adjusted To Their Approximate Positions Before Manually Operating The Door Or Before Applying Power To The Operator.

Warning!

Do not remove the cable ties from around the door head unit until the door is installed to the door frame and the Manaras Operator is properly installed to the door drive shaft. Without proper support, the door will drop with rapid motion and injury may occur.

Before using the Manaras Operator's UP/DOWN manual chain or switch controls, ensure the shipment cable ties and drive shaft safety brackets are removed from around the door head unit.

15.1 Adjustment of Limit Switches

1. Open the cover of the electrical enclosure.
2. Manually raise the door to a nearly opened position using the Manaras manual chain. (**Section 14, Page 31, Manaras Manual Operation**)
3. Pull the traveling cam retaining bracket on the Open Position cam side and rotate the Open Position cam. **Refer to Diagram 15A, Limit Switches.**

Note: Turning the cam towards the center of the shaft increases door travel. Turning the cam towards the switch decreases door travel.

4. Manually rotate the Open Position cam until the lever activates the Open limit switch sufficiently so as to hear the switch click.
5. Release and engage the retaining bracket. Make sure that the bracket engages in the slots of both limit cams after each adjustment.
6. Manually lower the door to a nearly closed position and repeat **steps 3 through 5** with the Close Position cam.
7. Upon completion of all wiring connections, repeat **steps 2 through 6** above using the "Stop" button for adjustments of limit switches to their final, exact positions.

Diagram 15A Limit Switches

Cam Retaining Plate

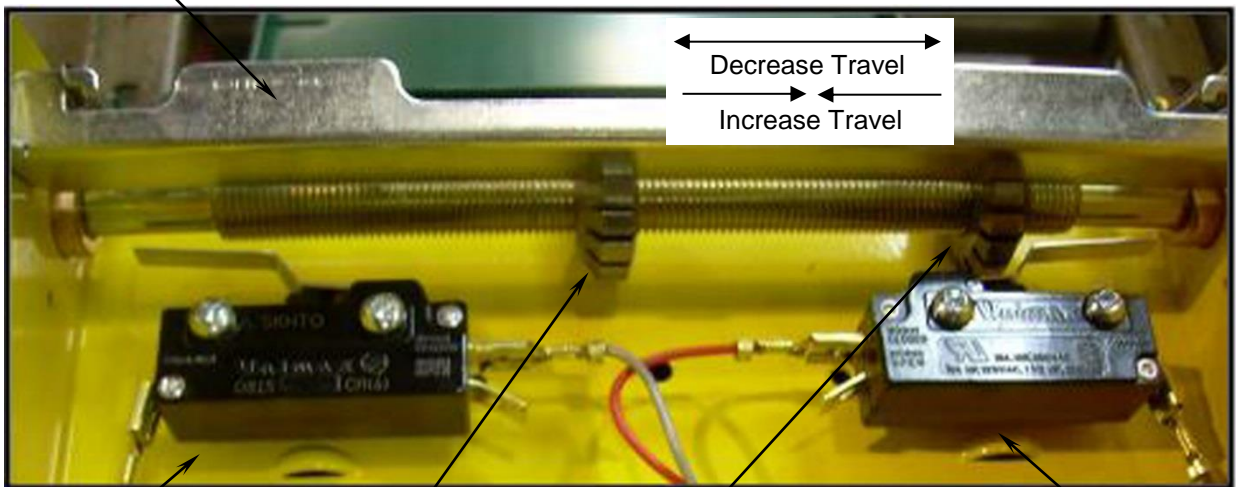

"Open" Limit Switch

"Open Position" cam

"Close Position" cam

Advanced "Close" Limit Switch

Warning!

NEVER PLACE HANDS OR TOOLS INSIDE OPERATOR OR NEAR
DRIVE MECHANISM UNLESS POWER IS OFF.

16 Wiring Options to the Manaras Operator Terminal Block

For information on wiring the Manaras Operator, refer to the Manaras Installation and Instruction Manual provided with the door.

- **Radio Controls:** Consists of a radio receiver unit and remote transmitters. These controls consist of an RF signal being emitted on a "pulse" basis to a mated receiver tuned to the same "pulse" rate. Once the receiver accepts the code, a relay is activated closing a set of contacts.
- **Photo-electric units:** Can be used as opening and reversing devices. An infrared light is emitted from the control to a reflector and back. If, during closing travel of the door, the light beam is broken, the door will reverse to the fully open position.
- **Digital Keypad:** Consists of a control head which is pedestal mounted. Similar to a telephone touch pad it allows the selective coding of a four number series. Once the programmed series of numbers is received in their set order, a relay closes and completes a circuit.
- **Card Reader:** A magnetic-mechanical device which accepts sealed and coded cards. The cards trigger magnets to rise in the cartridge head, releasing a lock mechanism which allows a deeper insertion of the card. The card then contacts a switch that closes the circuit.
- **Key Switch:** Momentary contact will open door. Can be wall or post mounted for interior or exterior use.

NOTE: Certain accessory devices may require additional power wiring.

16.1 Wiring Switches

To Operate Door:

Depress the "Close" button on the Open/Close/Stop switch. Door curtain will unroll to 'closed' position.

Depress the "Open" button on the Open/Close/Stop switch. Door curtain will open to 'Open' position.

Depress button to open or close door as desired.

Open and close the door a few times to test door operation and remove any wrinkles in the door curtain.

If you detect any problems, STOP. Disconnect electrical power. Contact your distributor for assistance.

16.2 Two (2) Position Switch

MANARAS TERMINAL BLOCK

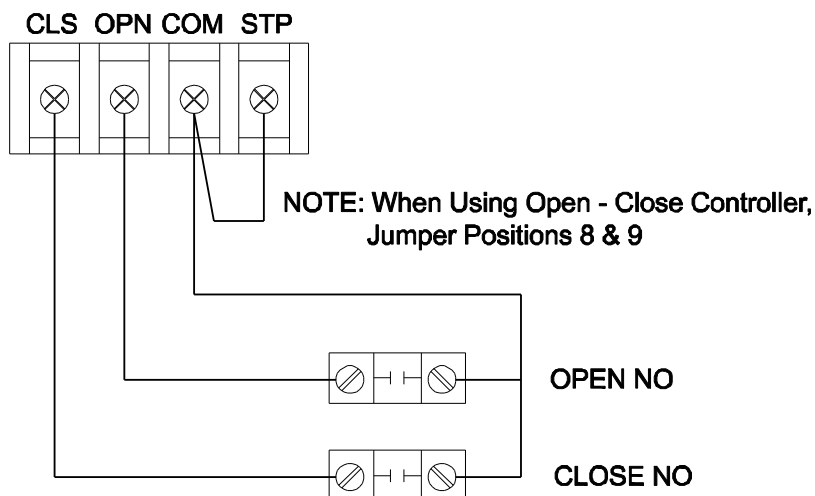

16.3 Three (3) Position Switch

MANARAS TERMINAL BLOCK

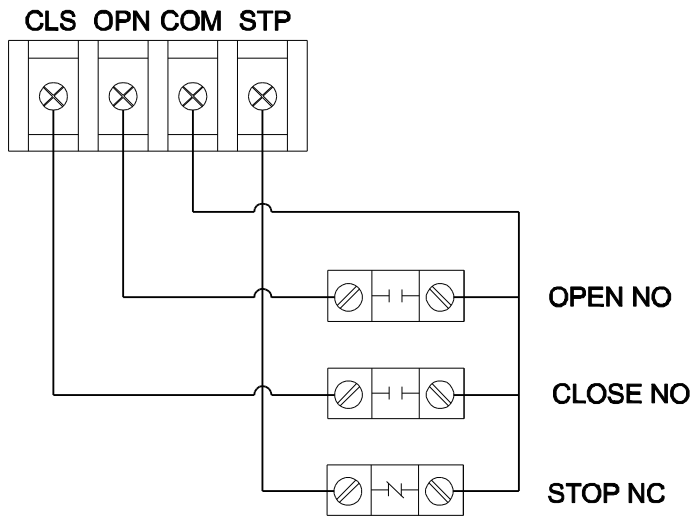

16.4 Three (3) Position Switch With Key Lock

MANARAS TERMINAL BLOCK

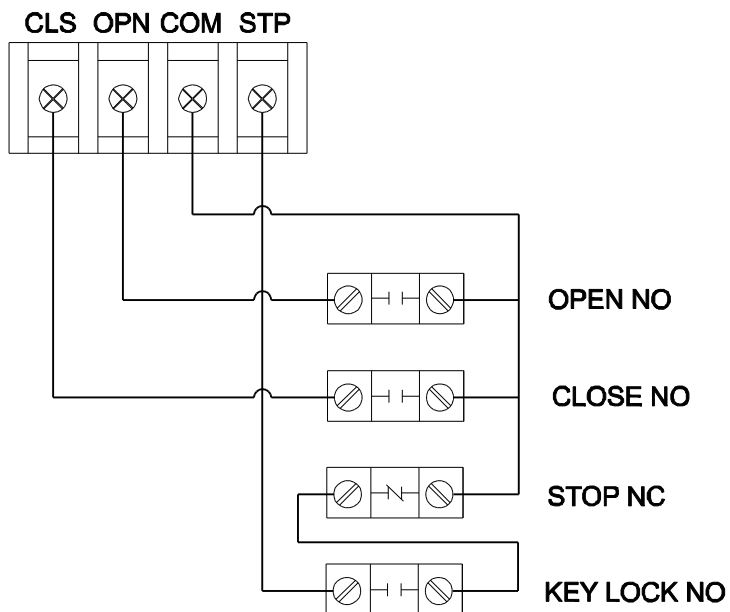

16.5 BEA Receiver

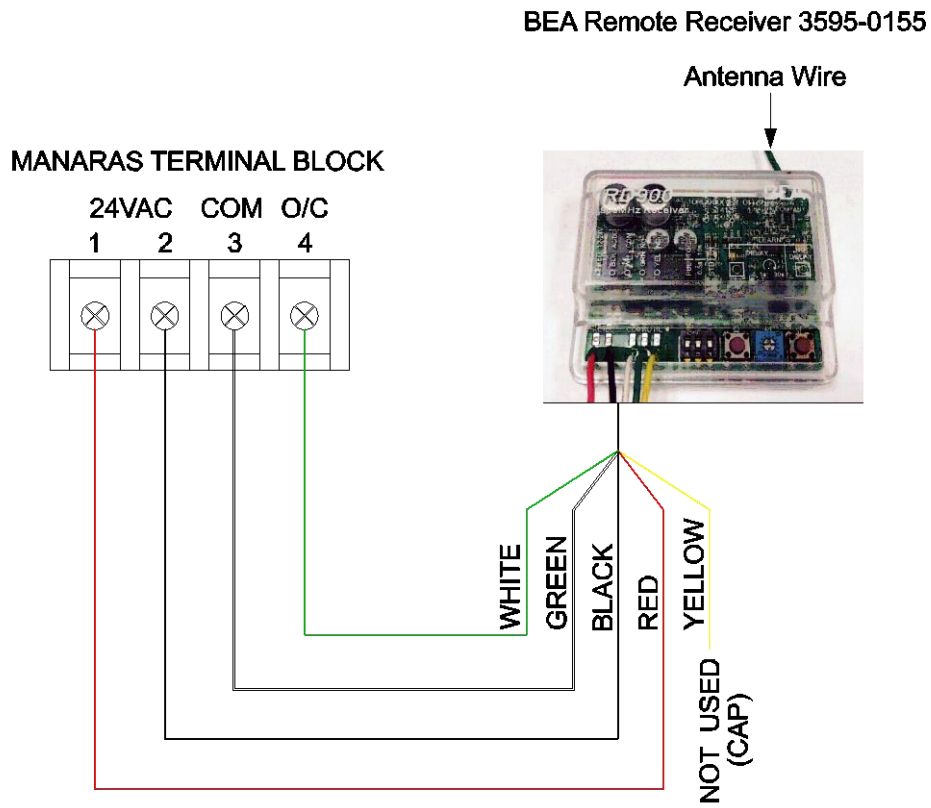

17 Manual Chain Hoist

The Chain Hoist can be installed on left or right side of door.

The Safety Bracket is designed to lock the drive shaft (during shipping and installation) to prevent injury from rapid drop of the door curtain. A Safety Bracket is installed on each end of the head unit. Removal of the first bracket should only be done after door is secured to structure.

⚠ CAUTION!

Only remove the Safety Bracket from the side of the door that gets the hoist, once door is secured to wall. The Safety Bracket on the opposite side should only be removed after the hoist is installed. **Removal of both Safety Brackets without hoist installed can cause serious injury or damage.**

17.1 Chain Hoist Installation

17.1.1 Removal of the First Safety Bracket

1. Remove cable tie and tag. Not shown below.
2. Remove the shaft locking hardware. See Diagram 17A, Detail B, Item 1.
3. Remove the two bolts holding Safety Bracket to Head Unit. See Diagram 17A, Detail B, Item 2.
4. Retain hardware and bracket for later use.

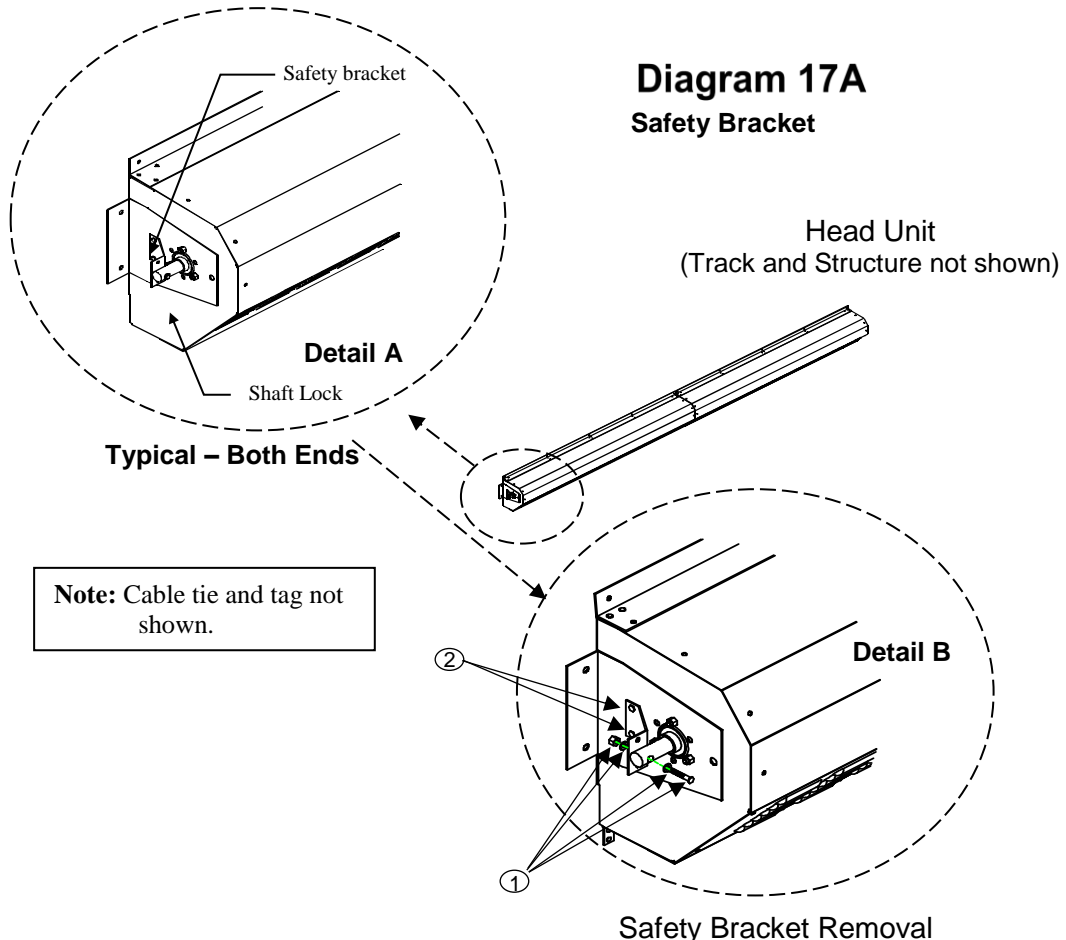

17.1.2 Chain Hoist Mechanism Installation

1. On end of door, position U-shaped mounting bracket (6421-9393) over shaft. **See Diagram 17B.**
2. Align bolt holes of bracket with attachment holes in door.
3. Insert bolts through cut-out openings of mounting bracket.
4. Securely attach mounting bracket to door.
5. Position Chain Hoist onto mounting bracket. Align bolt holes of hoist with holes in bracket.
6. Securely fasten Chain Hoist to bracket with bolts provided.
7. Securely attach Catch Bracket to wall with self-tapping screws provided.
8. Securely hook chain into Catch Bracket as shown below.
9. Add appropriate chain direction label from hardware kit to side of track near the chain at a height of 4ft from the ground. Use label 4501-9603 for chain hoists mounted on right side of door and 4501-9602 for chain hoists mounted on left side of door.

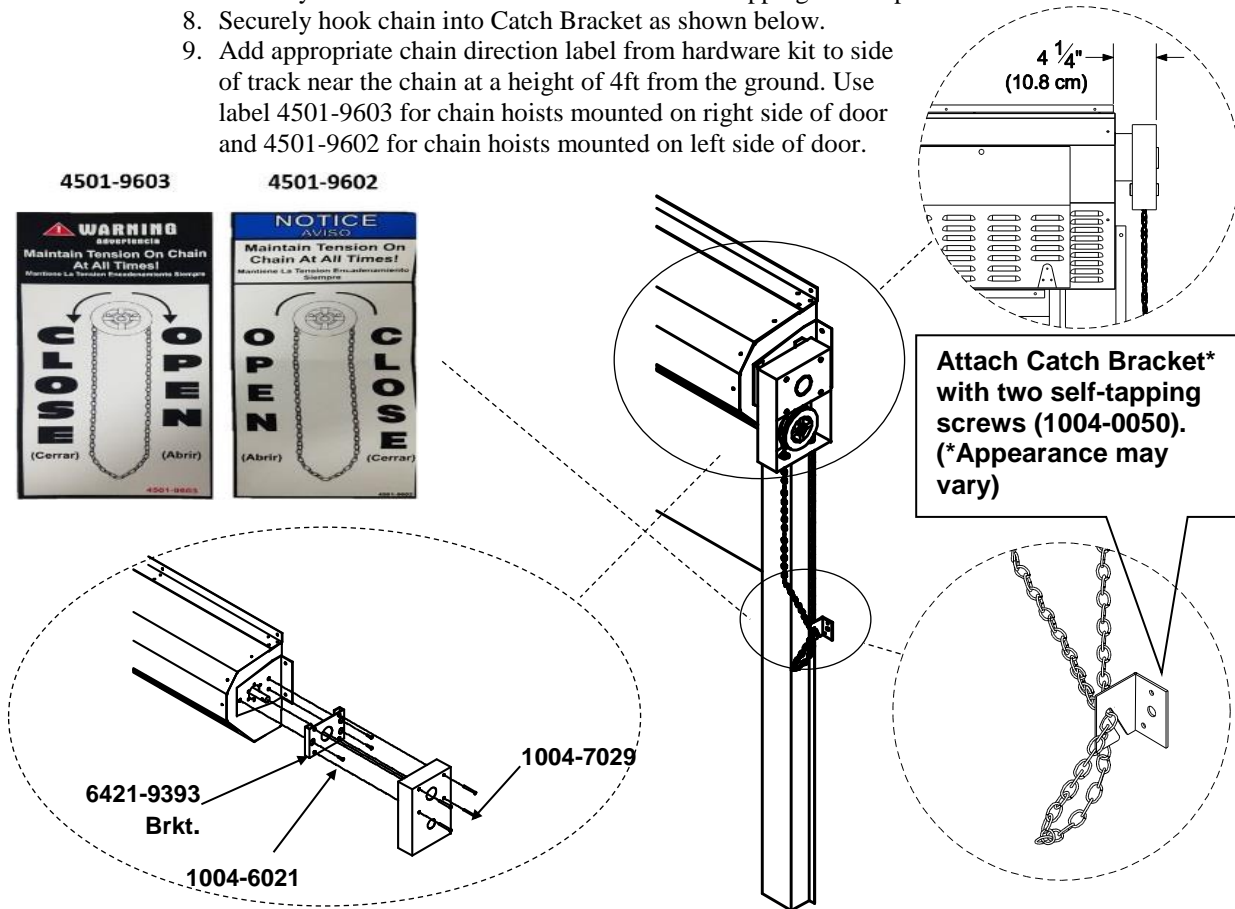

Diagram 17B
Chain Hoist

17.1.3 Removal of Second Safety Bracket After Hoist Is Installed and Secured

1. Remove cable tie and tag. Not shown.
2. Remove the shaft locking hardware. See Diagram 17A, Detail B, Item 1.
3. Remove the bolts holding Safety Bracket to Head Unit. See Diagram 17A, Detail B, Item 2.
4. Retain hardware and bracket for later use.

Hoist installation complete.

! Warning!

NEVER RELEASE CHAIN!

If Chain Is Released, Door Will Drop With Rapid Motion. Injury May Occur If Chain Is Released!

17.2 Operation of the Manual Chain Hoist

Caution!

NEVER RELEASE CHAIN WHILE DOOR IS BEING RAISED OR LOWERED!

You must maintain tension on chain while door is lowered
to prevent rapid drop (closing) of the door.

1. Carefully pull chain to open (Raise) door.
2. When door is fully raised, securely hook chain into Catch bracket as shown in Chain Hoist Instructions.
3. To Close (Lower) door, *securely hold chain*. Unhook chain from bracket. Gradually close door.

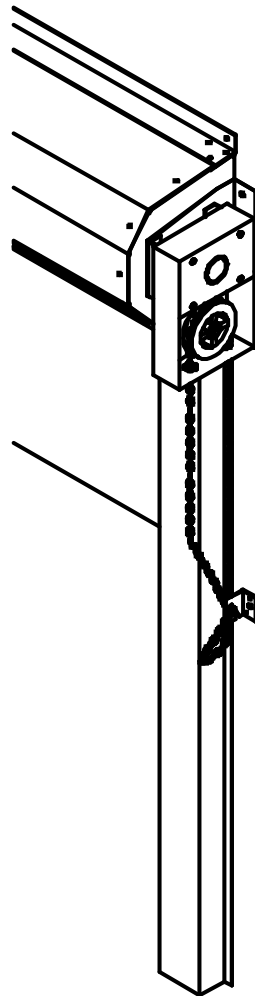

18 Brother Operator

The Brother Operator will be mounted at the manufacture. **Diagram 18A** shows a RS-500/600 Series Door with a Brother Operator. Refer to wiring diagrams included in this manual and 4801-5156 RollSeal SC-325 & SC-650 Controller Manual for Brother Operator wiring.

Diagram 18A

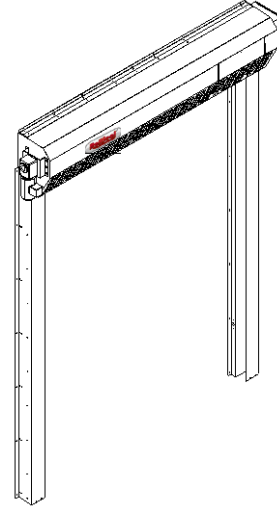

19 Installation of RS-500/600 Series Doors Freezer Kit



Installation of a RS-500/600 series Automatic Freezer Door involves connecting to the Smart Controller SC-325 or SC-650 that connects to the AC power, the door motor, the Up/Down button, and the safety beam, plus connecting the Condensation Management System (CMS) Unit and associated duct work. Other accessories can be added such as a remote IR sensor, a remote radio link, and door movement indicators such as lights and bells.

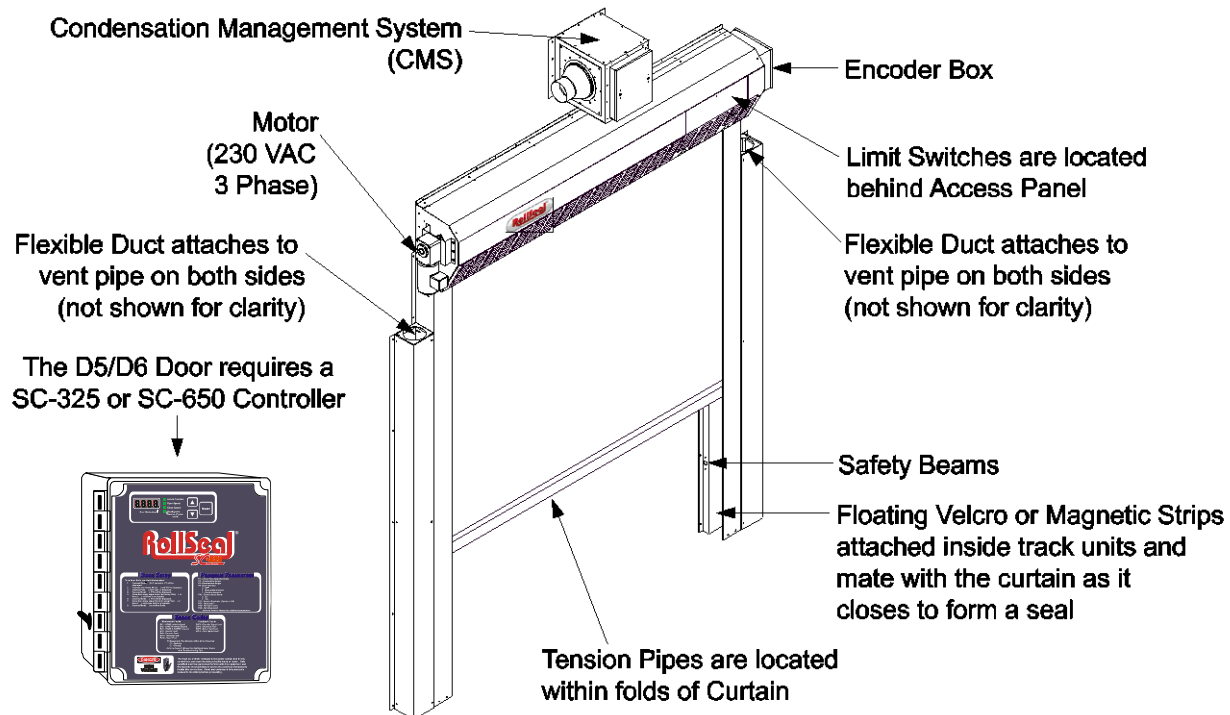

Note: Impact Resistant Pipes are available for door sizes up to 12 feet
Soft Tension Pipes are available for door sizes up to 10 feet

19.1 Tools Required

3/8 in. (10 mm) Power screwdriver (portable) 3/16 in. (5 mm) Drill bit and power drill 3/8 x 1 in. Bolts and nuts (supplied)	Socket Hammer Tape measure Carpenter's level
<i>NOTE: Other Tools May Be Required According To Installation.</i>	

19.2 Overview

The RS-500/600 Freezer Door is shipped with pre-assembled vertical members (left track and right tracks), with floating magnets, and a pre-assembled horizontal member (head unit). When components are received, check for damaged, loose or missing parts. If there are damaged or missing parts contact your RollSeal distributor immediately. Please read and understand all instructions in this manual before beginning installation. After the door has been assembled and attached to the door framing per instructions in **Section 12, Page 18** of this manual it is necessary to install the Condensation Management System (CMS) and ducts to complete the freezer door installation.

20 Installation of Condensation Management System and Ducts

Install the Condensation Management System at the top of the Freezer Door approximately in the center of the door as shown below. Install the 5/7" Duct Adaptor in the intake side of the Condensation Management System.

Carefully run the duct work to the two couplings on the left and right track of the door. Fasten each end of the duct with hose Clamps.

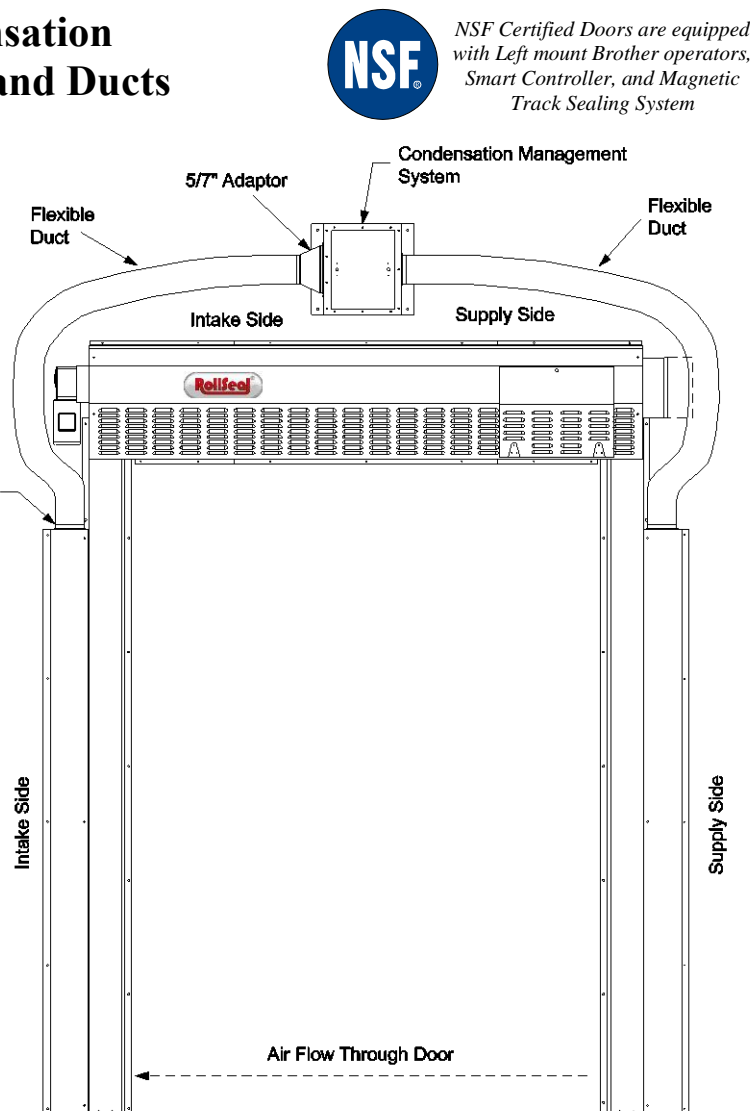
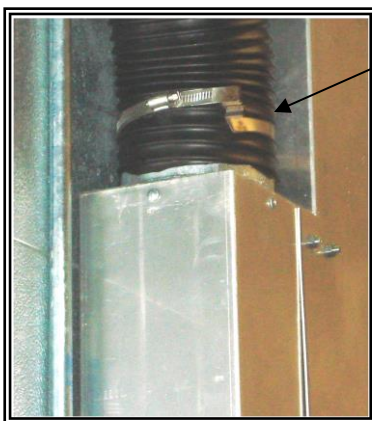

20.1 Wiring the Condensation Management System for RS-500-600 Series Doors

The CMS (Condensation Management System) is designed to operate continuously.

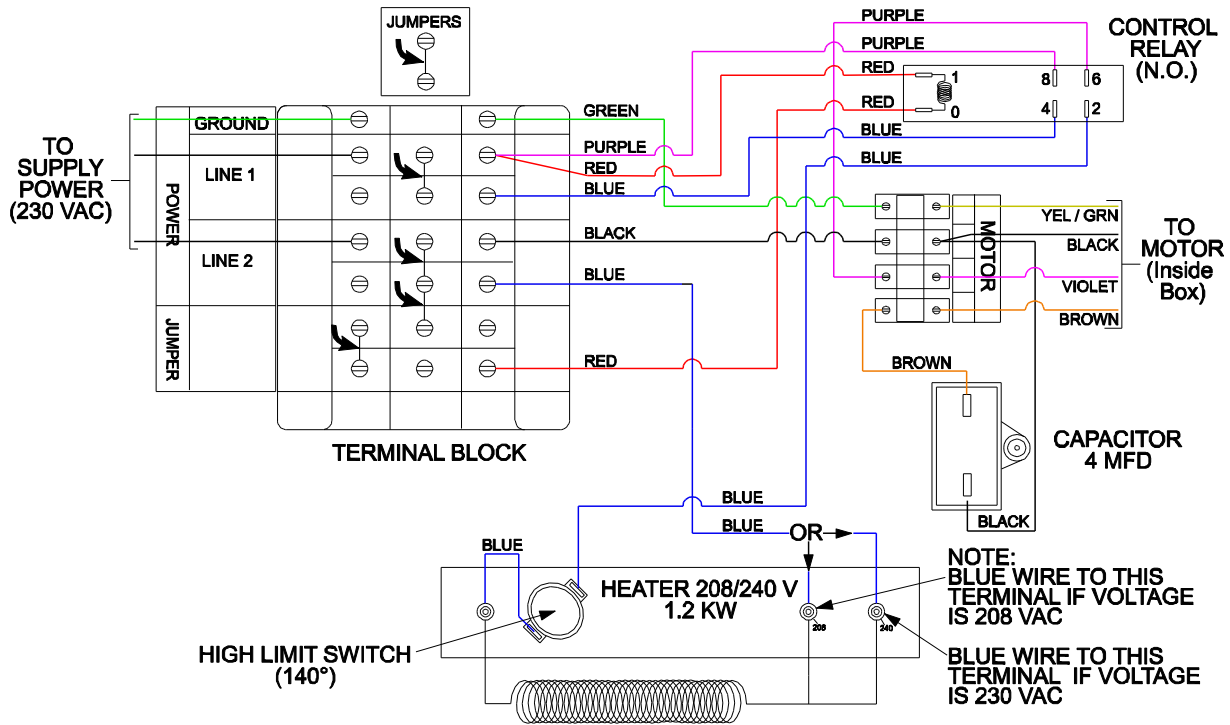

21 Connecting Electrical Power to RS-500/600 Series Doors

Refer to the appropriate Operator Manual (4801-5156 RollSeal SC-325 & SC-650 Controller Manual or the Manaras Installation and Instruction Manual).

22 Electrical Connections for RS-500/600 Cooler Door

The Cooler Setup is designed to enable door installers to completely install and test door operation. Electrician is still required to connect power to door, but all switch and interface connections are made to be pluggable for ease of installation.



NSF Certified Doors are equipped with Left mount Brother operators, Smart Controller, and Magnetic Track Sealing System

Diagram 22A

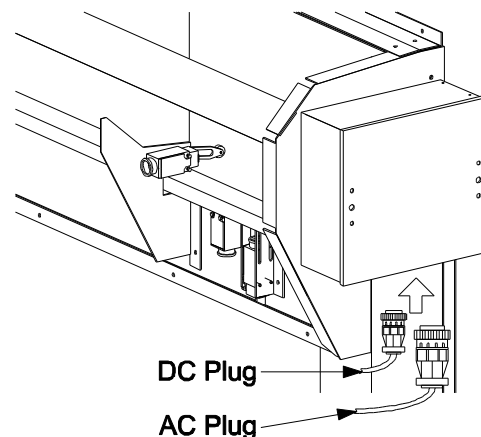

22.2 Connection of Controller to Head Unit.

1. Mount controller at desired location within 3' of junction box on Head Unit.
2. Controller has an AC and DC harness prewired that connects to head unit as shown in **Diagram 22A**.

22.3 Installation of Prewired Switches

Cooler Switches are prewired with a CPC quick connect. Prewire Switches have two switch assemblies: an Outside Cooler Switch with a 6 foot harness and an Inside Cooler Switch with a 1.5 foot harness. Switch assemblies are available in horizontal and vertical orientations. Shown below in Diagram 22B is vertical orientation.

1. Connect Outside Switch to Controller with CPC connection. Push and turn CPC connector until it's completely locked in place.
2. Mount Outside Switch in desired location on cooler wall.

Note: Cover removed for mounting.

3. Drill 1" hole through Cooler Wall to run Inside Switch out to connect to Outside Switch.
4. Route Inside Switch Harness through hole and connect to bottom of Outside Switch with CPC.
5. Mount Inside Switch in desired location.

Note: Cover removed for mounting.

6. Install Conduit Straps on conduit as required. Mount a strap close to CPC connection to prevent tampering. Insure conduit is run in a way to prevent moisture from running into electrical units.
7. Seal hole

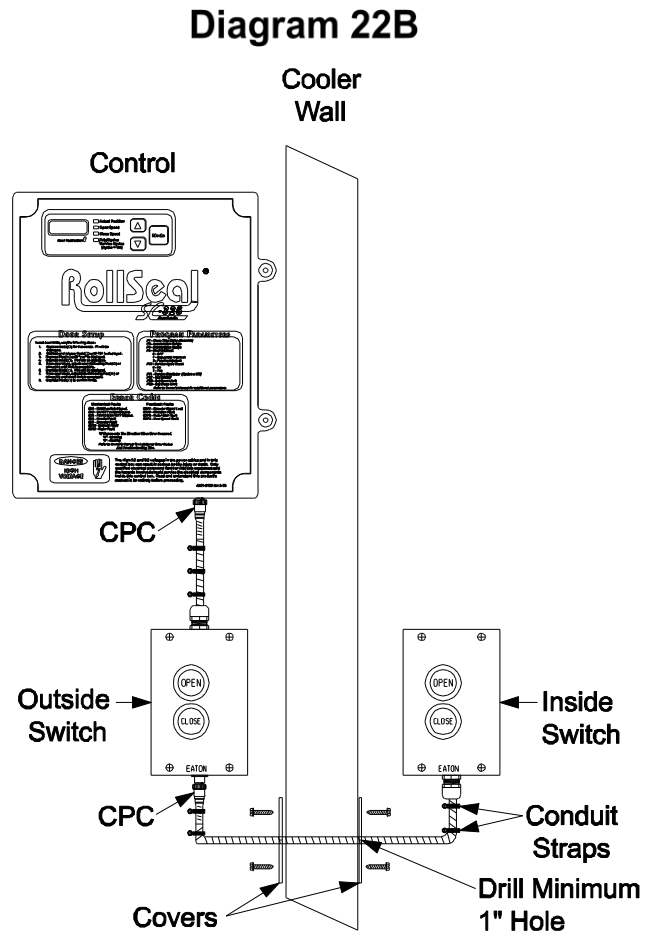

22.4 Power Connection with Disconnect

1. Mount Disconnect in desired location.
2. Connect harness from Disconnect to Control with CPC. Push and turn to lock in place.
3. Remove Disconnect cover. Switch must be in off position to remove cover.
4. Connect conduit and electrical supply to Disconnect.
5. Connect 115V power supply to Disconnect as shown in Diagram 22C.
6. Place cover back on Disconnect.
7. Add conduit straps to conduit.

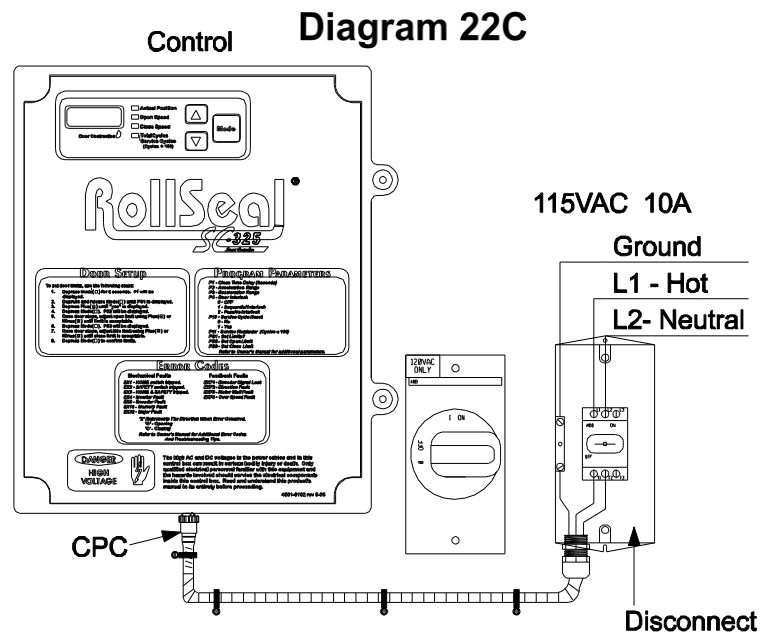

22.5 Preparation for Operation

Refer of the RollSeal SC-325 and SC-650 Controller Manual (4801-5156) for more information on Controller Settings.

Note: If you detect any problems, STOP. Disconnect electrical power. Contact your distributor for assistance.

1. Insert fuse in Control.
2. Apply 115VAC power to Control and turn Control toggle switch on.
3. Set the Open and Close Limits:
 1. Depress the *Mode* button (●) for at least 5 seconds. P1 (Close Time Delay) will be then be displayed in the Display Indicator.
 2. Depress and release the *Mode* button until PS1 (Change Program Limits) is displayed.
 3. Depress *Up* (△) until “yes” is displayed.
 4. Depress the *Mode* button again (●). PS2 (Set Open Limit) will be displayed.
 5. The door will proceed to the open limit and then stop. Once the door stops, adjust open limit using the *Up* (△) or *Down* (▽) buttons until open limit is satisfactory.
 6. Depress the *Mode* button (●) again. PS3 (Set Closed Limit) will be displayed.
 7. The door will proceed to the closed limit and then stop. Once door stops, adjust this limit using the *Up* (△) or *Down* (▽) buttons until the close limit is satisfactory.
 8. Depress the *Mode* button (●) again and the controller will exit the programming mode and return to displaying the actual position.
4. Press “Open” button on Outside Switch. If the Door is set to automatically close, door will time out and automatically close if safety beams are clear. If the Door is set to manually close, press “Close” button on Outside Switch and door should close.
5. Press “Open” (and “Close” if required) a couple times to insure proper operation.
6. Repeat steps 4 and 5 for Inside Switch.
7. Verify Safety Beams reverse door when blocked during closing.
8. Verify Leading Edge Switch is operational.
9. Verify that Warning Light and Egress Buzzer (if applicable) are functioning properly.
10. Ensure Safety Pull Hook for Egress and Pull Hook Tether are mounted inside cooler and Manual Crank Handle for motor is mounted outside.

The door is now ready for operation.

23 Operation of RS-500/600 Series Doors With Brother Operator

NOTE: Refer to the RollSeal SC-325/650 Controller Manual for wiring and initial setup. After wiring the controller to the door, connect electrical power to the controller. The door is now ready for operation.

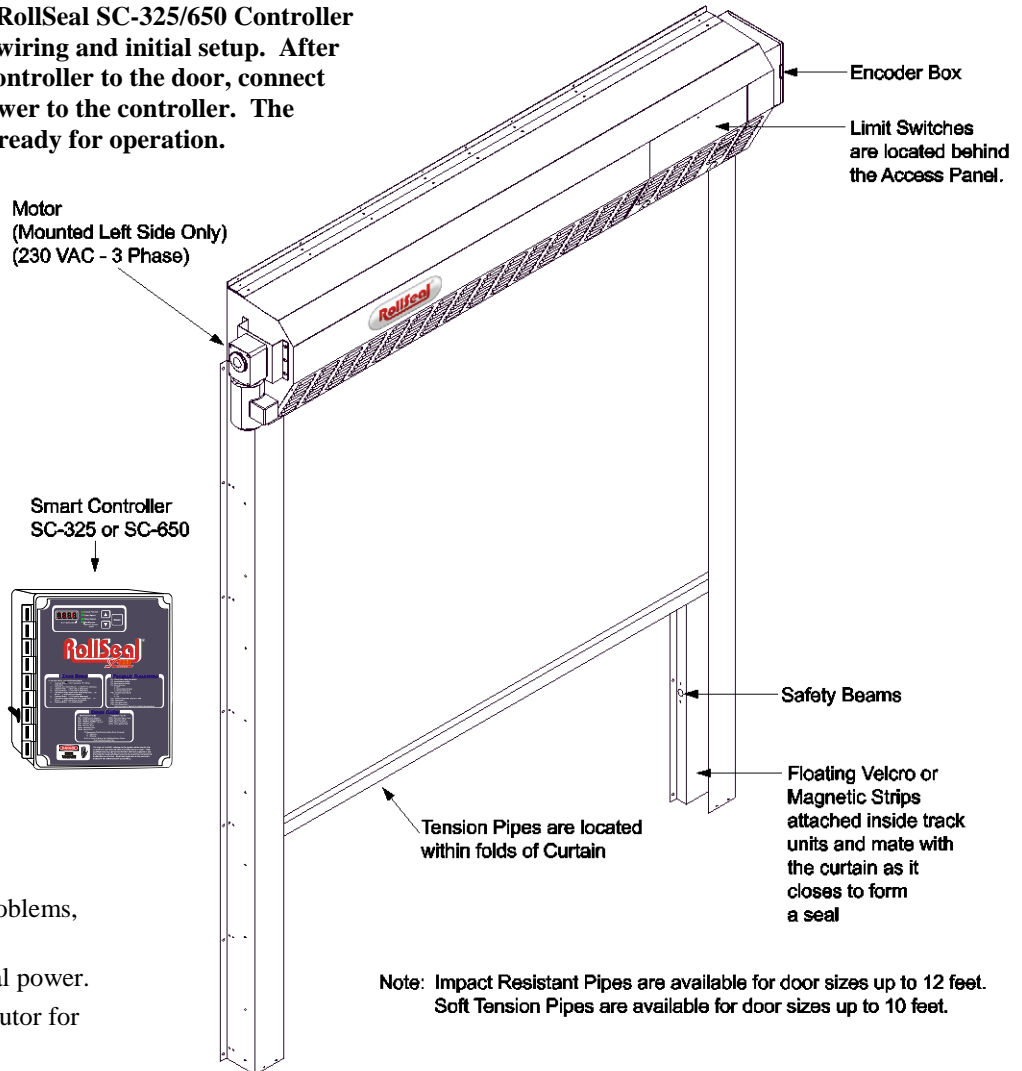

If you detect any problems, STOP.

Disconnect electrical power.

Contact your distributor for assistance.

The controller keeps track of the "open" and "closed" positions of the door by means of a mechanical encoder wheel that is located in the encoder box. The controller electronically counts steps as the wheel turns to keep track of the door position. The door seals by means of 'hook & loop' or 'magnetic' strips along the edges of the door curtain and vertical members.

23.1 Operation of a Standard RS-500/600 Series Door:

1. Depress "Open" switch button mounted on the wall. Door curtain will roll up to 'open' position and find "HOME" position and drop some to the set upper limit. If door was wired for "timer" it will count down from set delay and close on its own. If not on wired on "timed" function proceed to step 2 to close.
2. Depress "Close" switch button. Door curtain will roll down to 'closed' position of lower limit and stay
3. Depress button to open or close door as desired.
4. Open and close the door a few times to test door operation and remove any wrinkles in the door curtain.

23.2 Operation of RS-500/600 Series Door with Optional Freezer Kit



NSF Certified Doors are equipped with Left mount Brother operators, Smart Controller, and Magnetic Track Sealing System

1. Depress “Open” switch button mounted on the wall.
Door curtain will roll up to 'open' position and find “HOME” position and drop some to the set upper limit. If door was wired for “timer” it will count down from set delay and close on its own. If not on wired on “timed” function proceed to step 2 to close.
2. Depress “Close” switch button. Door curtain will roll down to 'closed' position of lower limit and stay
3. Depress button to open or close door as desired.
4. Open and close the door a few times to test door operation and remove any wrinkles in the door curtain.

***Refer to the 4801-5156 SC-325 and SC-650 product manual for additional smart controller information.**

PROGRAM PARAMETERS	
P1 - Close Time Delay (Seconds)	P7 - Refresh Door Limits
P2 - Acceleration Range	P10 - Service Cycle Reset
P3 - Deceleration Range	0 - No
P4 - Door Interlock	1 - Yes
0 - Off or Optional Door Motion	P11 - Service Reminder (Cycles x 100)
Light(s)/Buzzer(s)	P12 - Input Status
1 - Sequential Interlock	PS1 - Set Limits?
2 - Passive Interlock	PS2 - Set Open Limit
3 - Freezer Mode - No Interlock	PS3 - Set Close Limit

24 Limit Switches

There are three limit switches located within the horizontal member mechanism. See **Diagram 24A**. These switches are attached to levers that contact the curtain.

Diagram 24A

The **Home Switch** establishes the 'open' reference position of the door curtain. This creates the zero reference position, from which the encoder counts the position of the door.

The **Safety Switch** is a fail-safe switch that stops the curtain in the unlikely event of malfunction of the home switch.

The **Leading Edge Switch** is a switch that stops the curtain in the event of a doorway obstruction.

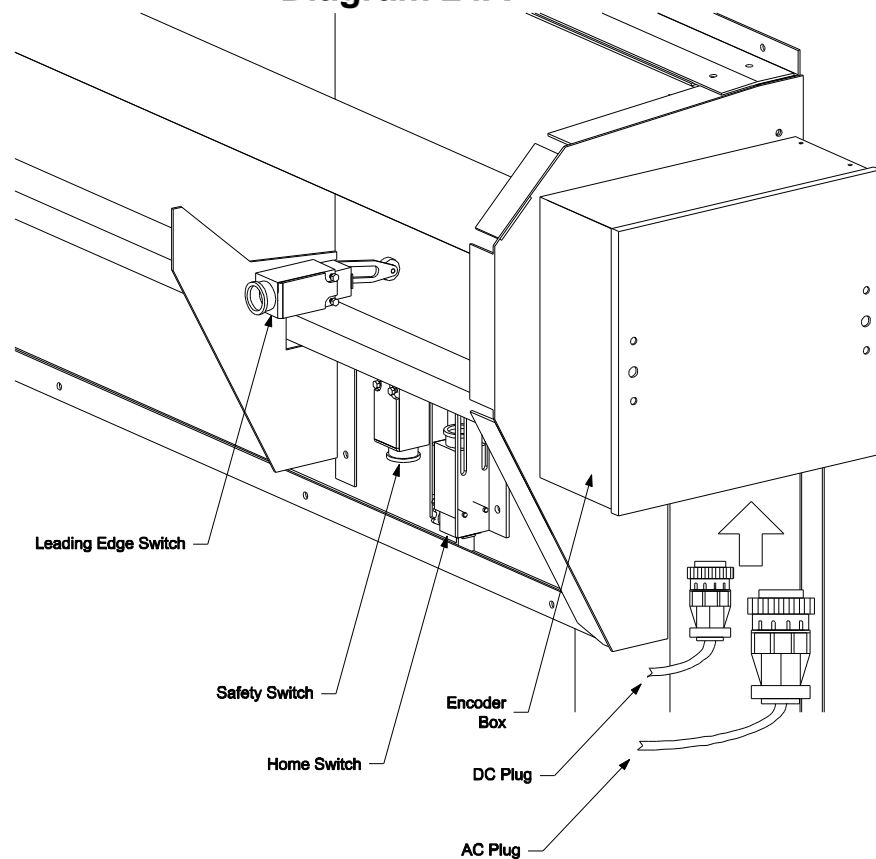

25 Manual Operation RS-500/600 Series Door With Brother Operator

The RS-500/600 Series Door can be operated manually in the event of a power outage or if there is a motor malfunction. To operate the door manually, perform the following instructions.



Warning!

Disconnect All Electrical Power To Motor Before Attempting
To Operate The Door Manually!



Warning!

The Curtain Is Released When Brake Lever Is Disengaged.
Do Not Disengage Brake Until Door Opening Is Clear!

If door is OPEN (door curtain raised) perform the following steps:

1. Locate brake lever at bottom of motor. (See diagram below).
2. Carefully release brake by flipping lever down.

CAUTION: Curtain will drop when brake is released.

If door is CLOSED (door curtain lowered) perform the following steps:

1. Turn power off to the controller
2. Locate brake lever at bottom of motor.
3. Carefully release brake by flipping lever down.
4. Motor shaft is accessible from bottom of motor. Use provided Crank Handle to rotate motor shaft.
5. Carefully turn motor shaft counterclockwise to raise door curtain.

Note: The drive (as viewed from the 'motor end' of door) is counterclockwise rotation of the motor shaft.

5. When door curtain has been raised to desired height, flip brake lever up to engage brake.
6. If you do not release the brake it could result in damage to the motor.

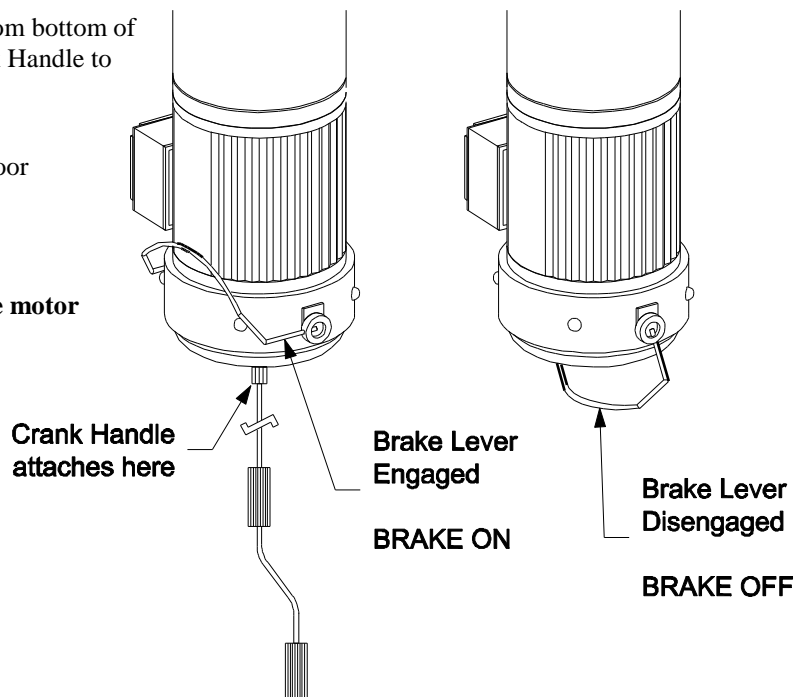

26 Adjustment of Brake (Brother Motor Only)

After extended operation of the brake lever, the brake may become worn. As the brake wears, some adjustment to the brake is required. Lettered diagrams below correspond to lettered instructions. Follow instructions to adjust brake:

1. Close door curtain to fully lowered position.
2. Engage Brake lever.
3. Disconnect electrical power to motor.
4. Remove four Phillips screws (A).
5. Remove cover (B).
6. Straighten the bent tab (C) of spider nut.
7. Tighten spider nut (C) snugly against blower wheel. Make sure a tab of spider nut is aligned with a notch in the shaft.
8. Bend tab (C) upward into notch of shaft.
9. Replace cover (B).
10. Replace four Phillips screws (A).
11. Disengage brake lever (D).
12. Adjustment complete.

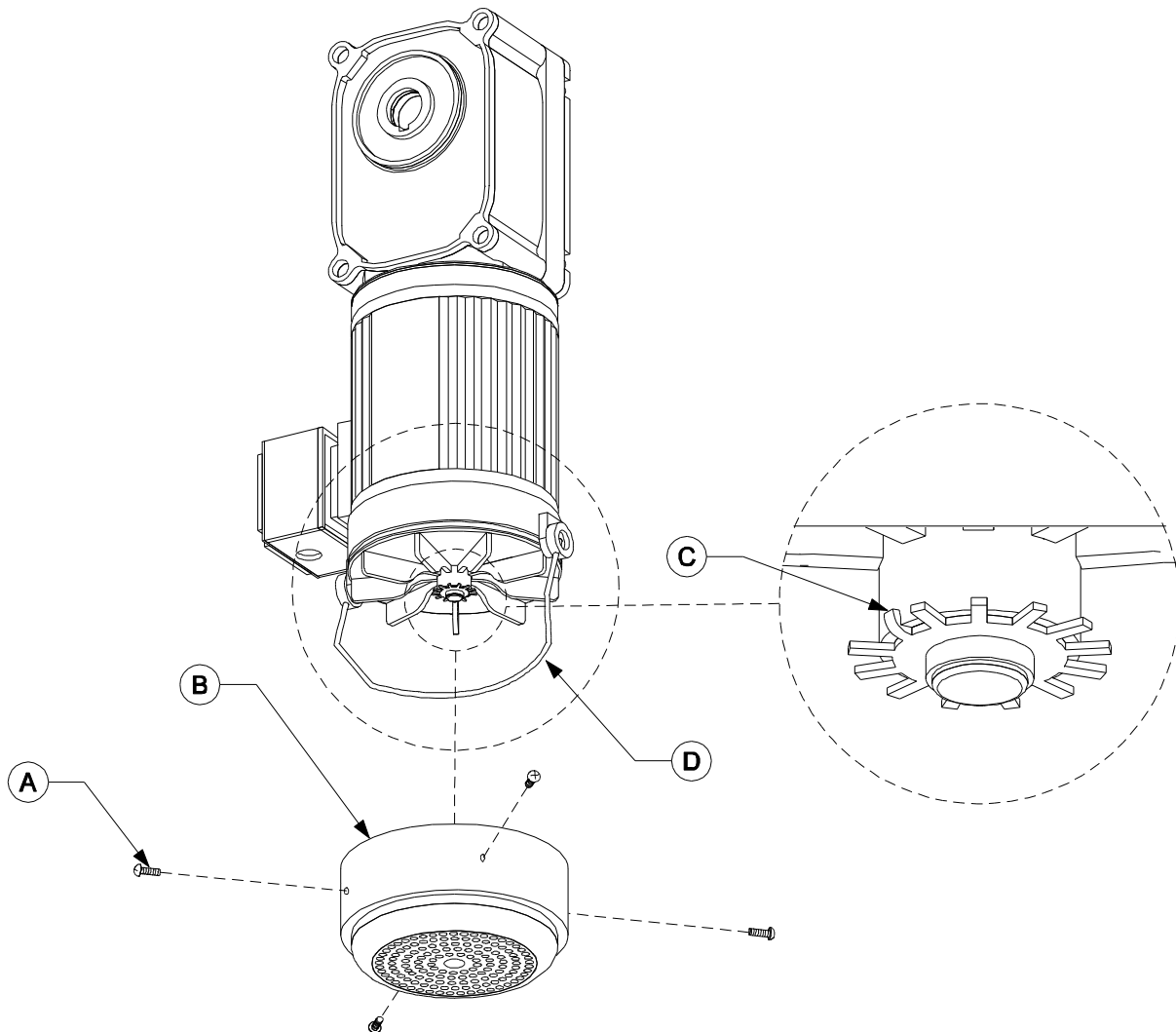

27 Door Panel Adjustments

During normal operation, the tension pipes should run in close proximity of each other. The clearance between the tension pipes should normally be between 1/4" to 1/2" (6.35 mm - 12.7 mm). See Detail 3 below. There are two situations pertaining to the tension pipes that may cause problems with door operation. If the tension pipes are too far apart, the tension pipes will not repel each other. This causes poor contact between the hook & loop or magnets. On the other hand, if the tension pipes are riding one another (i.e. touching one another), the door panel material does not flow evenly, thus leaving wrinkles in the panel instead of a stretched, smooth & even appearance.

Adjustment Procedures

The clearance between the tension pipes can be adjusted by raising or lowering the door panels. Each door has three panels: (1) the inside panel (panel facing the inside of building) is attached to the back plate. (2) The center panel is attached to the roller. (3) The outside panel (facing the outside of building) is attached to the front bar. Adjustments are made to the inside panel and/or the outside panel.

NOTE: The door must be in the closed position for panel adjustments. Ensure the panels are not damaged while removing or reinstalling the nuts and screws.

To adjust the height of the outside tension pipe, raise or lower the outside door panel by detaching the panel hook & loop from the front bar, and raising or lowering the panel. Then re-attach the panel loop to the hook on the front bar. Be sure to keep the tension pipe level during this procedure.

To adjust the height of the inside tension pipe, raise or lower the inside door panel by detaching the panel hook & loop from the back plate, and raising or lowering panel. Then re-attach the panel loop to the hook on back plate. Be sure to keep tension pipe level during this procedure. Install Tek screws through the panel material and into the back plate to securely hold the material in place.

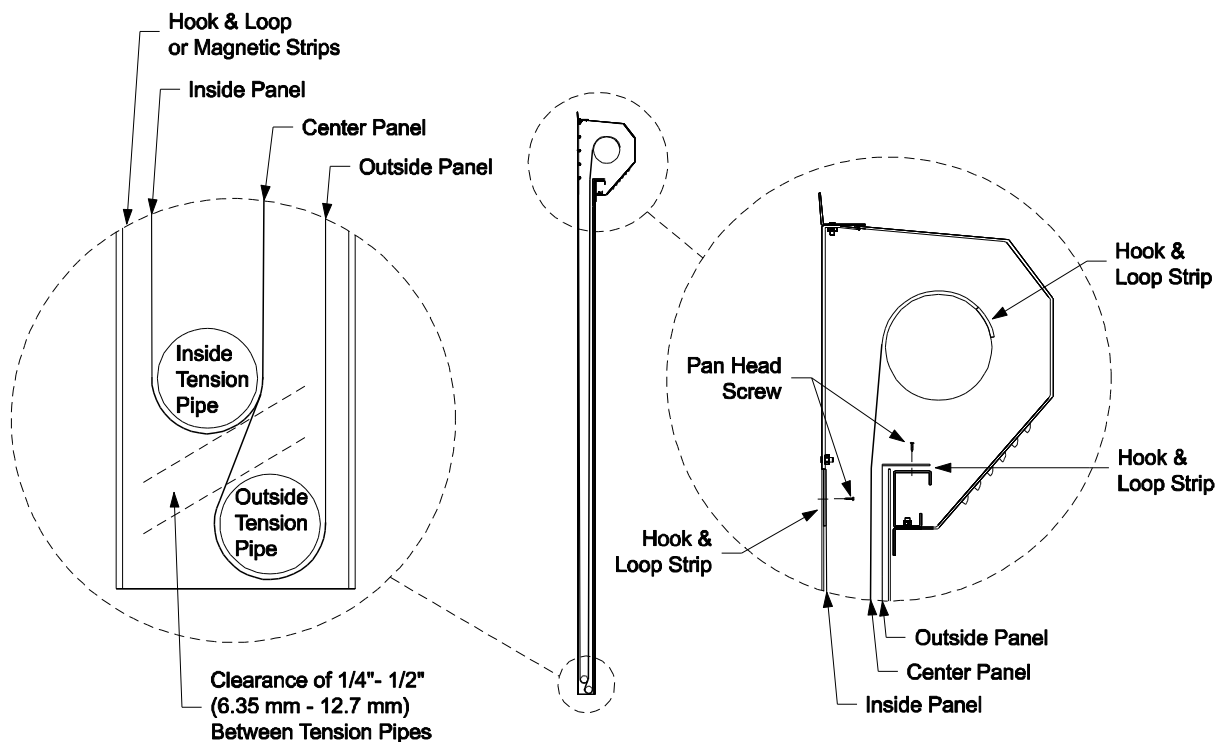

28 Removal of Existing Panel

1. Lower the panel to the floor.
2. Locate the door controller and turn off the power.
3. Remove and lower the cover from the door head unit.
4. Locate the 3 fabric sheets that make up the entire door curtain. See **Diagram 29A, Detail 2, Page 51**. The center panel has a hook & loop strip across the top. The center panel does not have magnets or hook & loop strips on the sides. The inside and outside panels have hook & loop strips at the top, and magnets or hook & loop strips along the sides of the panels. The outside panel may be identified as the longer of the two panels.
5. Mark the end of each sheet and along the edge of each sheet with a marker. This will prove vital to ensure you install the new panel sheets at the proper locations to alleviate major curtain adjustment.
6. Remove the 3 screws from each sheet (front, center, and back). See **Diagram 29A, Detail 2, Page 51**. Detach the hook & loop area of each sheet left to right, starting with front, then center, and then back sheets. Let the panel/curtain fall to the floor.

NOTE: If the door is equipped with an egress assembly you will see the yellow egress strap attached to a triangle piece of material with a quick-link connector. If it does not have this strap, read the notes below and proceed to step 8.

7. UN-screw the quick-link connector and allow the panel to lower to the floor.

NOTE: Observe how the tension pipes are installed before removal. They *MUST* be re-installed first, with one pipe in the front/outer pocket (closest to outside of the cooler) and the other pipe in the back/inside pocket. Locate the back pipe behind the triangle piece that is attached to the yellow strap. The front/outer pipe will always hang lower than the back/inside pipe.

NOTE: Failure to install properly could result in door sticking up.

8. Slide the 2 tension pipes out of their respective pockets. Remove the panel/curtain away from the door. You are now ready to install the new panel/curtain.

29 Installation of Replacement Panel

1. Place the new panel in front of the door opening and make sure the part number label is on the left side.

NOTE: If door is equipped with egress system yellow strap ensure that the strap is positioned to the front side of the back/inside panel to allow connection to the triangle piece of material with the quick-link connector.

2. Take the back/inside curtain (**Diagram 29A, Detail 1 & 2, Page 51**) and attach the material to the backplate placing material on the marks that were created during removal of old panel.
3. After the inside curtain has been attached, attach the egress strap (if equipped) to the triangle piece of material with the quick link connector.
4. Take the middle curtain (**Diagram 29A, Detail 1 & 2, Page 51**) and attach to the drive pipe.
5. Take the outside curtain (**Diagram 29A, Detail 1 & 2, Page 51**) and attach to the top bar.

NOTE: Ensure all roller switches (home, safety and leading edge) are pointing down.

6. After the curtain has been secured, install the bottom pipes in the curtain as shown in **Diagram 29A, Detail 3, Page 51**. The front pipe should be installed first. Then the back pipe is placed in front of inside panel but behind the yellow strap and triangle piece of material. It should be above the front pipe.
7. Ensure all panels are inside the tracks on both sides. Turn controller on and set to JOG mode by holding both arrows at the same time until you see "JOG" on the display. JOG up and down, using up and down arrows to straighten the panel. Exit JOG mode by holding both arrows at the same time. Run the door as normal.

Diagram 29A Curtain Installation

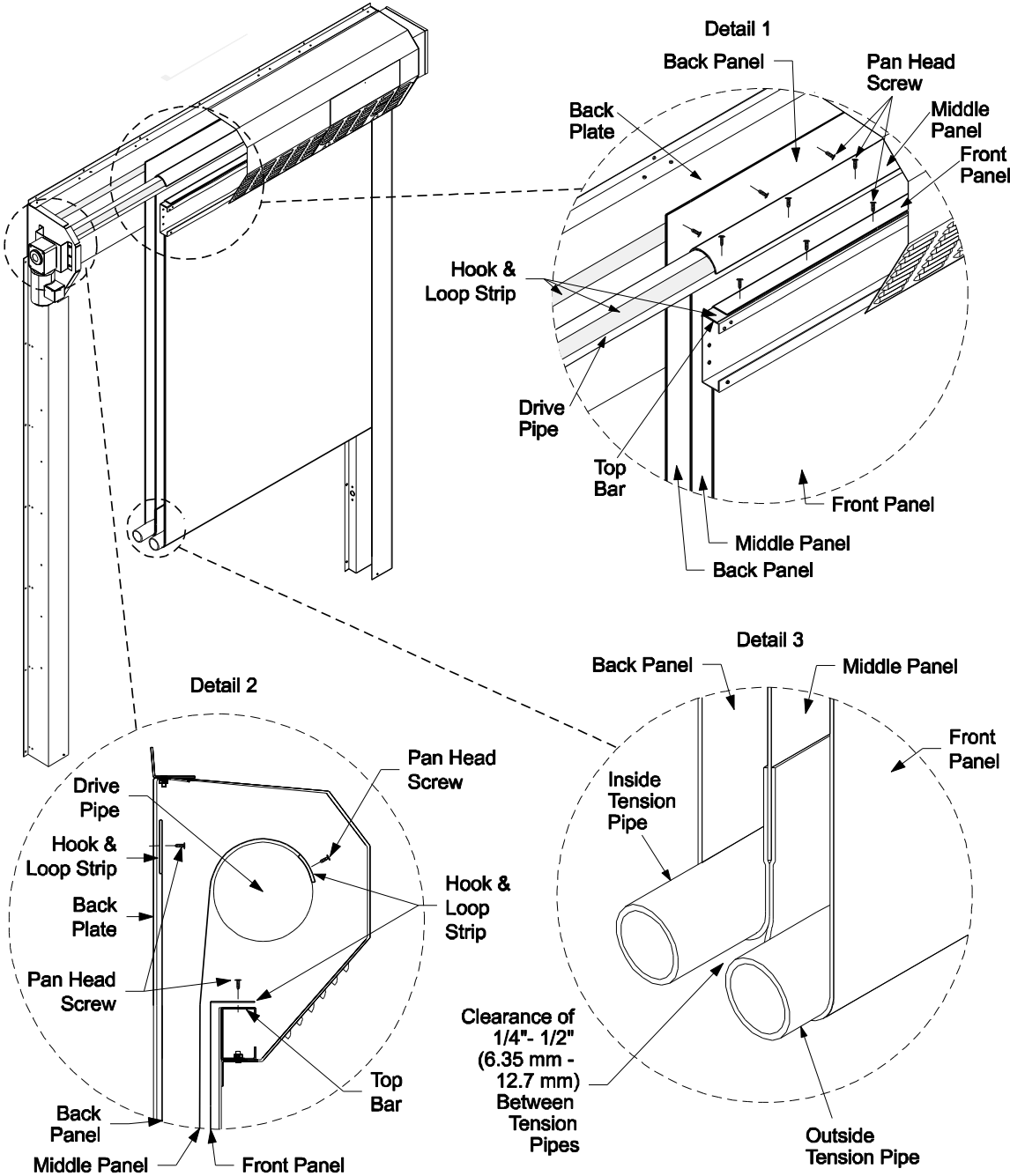

30 Cleaning Panels and Windows

Panels and Windows can be cleaned using a solution of cold to warm, mild soapy water and a cloth.

Wipe off the soiled area to remove dirt particles. Using a cloth gently wipe the panel and window with the soapy solution. Thoroughly rinse the area with pure cold or warm water to remove soap.

Dry off thoroughly with a dry cloth. **DO NOT ROLL-UP the panel onto itself without making sure it is completely dry!!!**

DO NOT USE: Solvents or strong alkaline cleaners. Use of these products could cause damage.

If in doubt about a particular cleaning solution, please do not hesitate to contact customer service for our recommendation.

31 Optional Door Features

31.1 Warning Indicator Light (Optional Feature)

Any time the cooler door is opening or closing, this light will flash indicating movement of door.

Note: On the SC-325 and SC-650, P4 setting in program mode must be set to 0 for proper operation.

Note: This feature will not work on Interlock or Freezers using CMS unit.

31.2 Egress Strap (Optional Feature)

The Emergency Egress feature provides a simple and convenient way to open door in emergency situation from inside the cooler should the door motor become inoperative due to a power failure or other conditions. The Emergency Egress Strap is located at center top of door. The door is opened by using the Emergency Egress Tool to hook D-Ring and pull strap down. Strap may be pulled by hand also. As strap is pulled, the door will open up enough that person can exit cooler safely.

31.3 Egress Buzzer (Optional Feature)

In the event the Egress Strap has been pulled, a buzzer will sound from the Head Unit as long as door has power. To turn buzzer off, the egress strap must be fully reset.

See **Section 32.3** for information on re-setting the Egress Strap.

31.4 Soft Tension Pipes (Optional Feature)

Soft Tension Pipes are designed to reduce or eliminate injury from impact of tension pipe. Available as an optional feature, existing doors can be upgraded. The pipe design helps to insure proper sealing of the door. Soft Tension Pipes are available for door sizes up to 10 feet.

31.5 Impact Resistant Tension Pipes (Optional Feature)

The Impact Resistant Tension Pipe is more flexible than our standard Tension Pipe. Impact Resistant Tension Pipes are available for door sizes up to 12 feet.

32 Emergency Egress (Optional Feature)

The Emergency Egress feature provides a simple and convenient means of exiting a Roll Seal RS-500 Door from the inside of the structure should the door motor become inoperative due to a power failure or other conditions.

32.1 Installation

Install the Egress Tool Retainer (1040-8400) to the left or right side outside of door jamb. For a wood framed door jambs use #10 x1" screw (1004-1386). For a metal framed door jamb use #8x1/2 Tek screw (1004-2492). See **Diagram 32A**.

The Egress Tool Tether (1040-8401) provides a means of attaching the egress hook to a location on the wall to prevent loss of the egress hook. This tether provides up to eight feet of cable. It can be mounted anywhere necessary to allow reach, hook, and pull of the Egress D-ring. The tether can be used on doors up to 10' x 10'. Attach the Tether with four (4) 1/4" phillips screws (1004-2068).

Diagram 32A

Install the Emergency Egress Tool Retainer on the door jamb

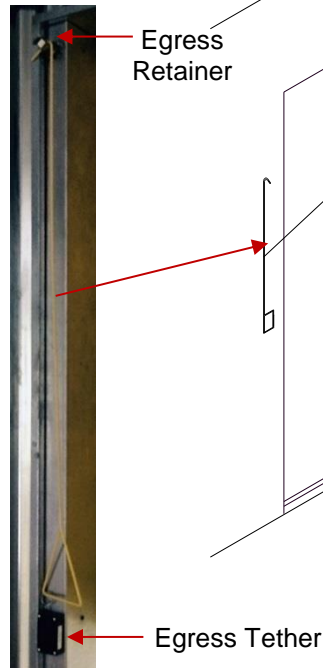

Diagram 32B

Diagram 32C

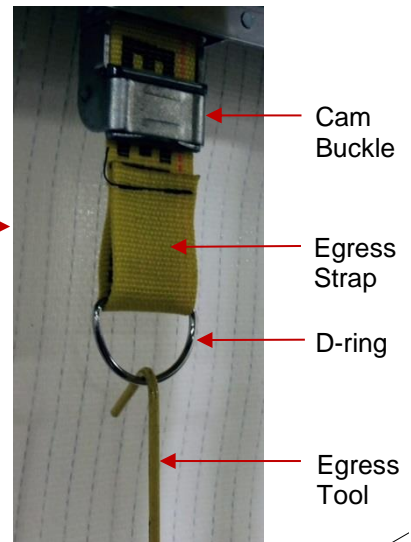
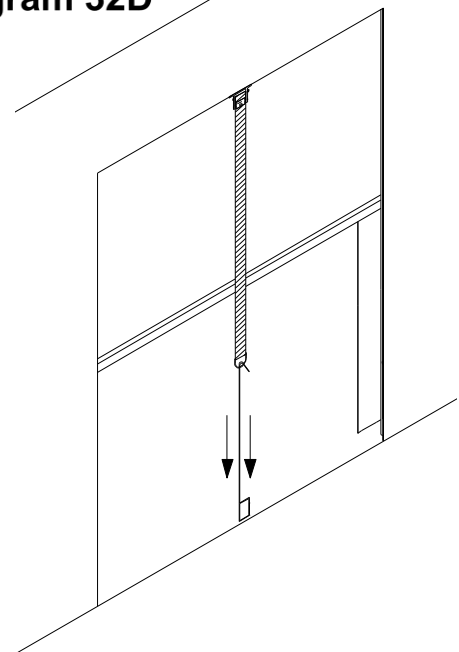

Diagram 32D



32.2 Exiting (Opening) The Door

1. Remove Emergency Egress Tool from the retainers on the side of the door.
2. Connect the hook end of the tool to the D-Ring on the top of the door frame. See **Diagram 34B** and **Diagram 34C**.
3. Pull down on the Egress Strap. The Door will raise approximately half way up. The door will open enough for a person to exit the structure. See **Diagram 32D**.

32.3 Resetting (Closing) The Door

After the RollSeal RS-500 Door is opened by using the Emergency Egress Strap, the door must be carefully re-set to ensure proper operation in the future.

CAUTION!

When the Cam Buckle is released, the door will rapidly close unless tension is held on the strap. Keep fingers away from buckle while closing.

1. Firmly hold strap. See **Diagram 32F**.
2. Press the Cam Buckle Release. See **Diagram 32G**.
3. Gradually feed strap through Cam Buckle until door is closed at bottom and D-ring is in the position shown in **Diagram 32E**.
4. Return Emergency Egress Tool to retainer for future use.
5. Cycle the door up and down in normal operating mode to ensure proper re-setting of the door. Adjust if necessary. Door should now function normally.

Diagram 32F

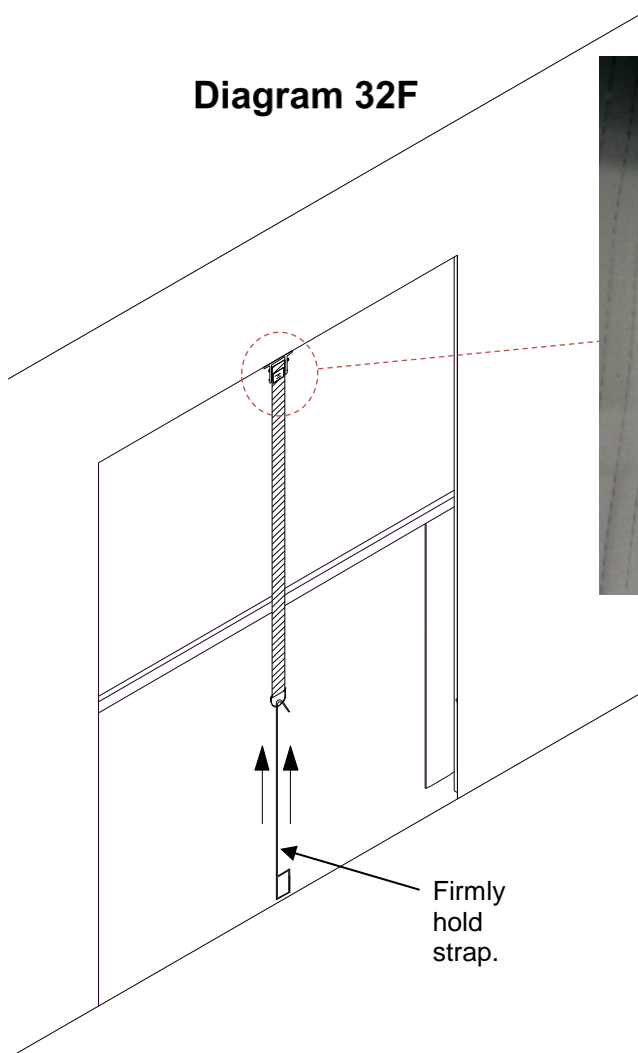
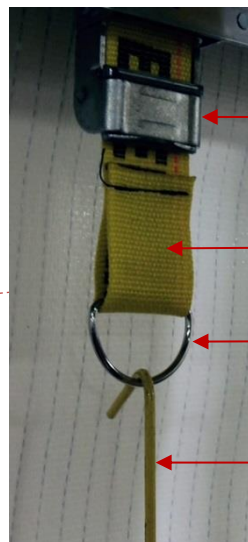

Diagram 32E



NOTE: This view shows the Cam Buckle as seen from the back of the door when the Egress Strap has not been pulled.

Diagram 32G

Cam Buckle Release

NOTE: The Release for the Cam Buckle is located on the panel side of the Buckle. This view shows the Cam Buckle as seen from the front of the door.

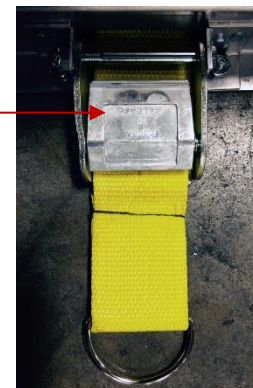

33 Egress Strap Removal/Re-Installation

33.1 Removal

1. Remove the door's head unit cover
2. Locate the door controller. Place the door in the JOG mode by holding the Up and Down arrows on the controller at the same time until you see "JOG" in the controller's display.



Warning!

Failure to stop the door when nearing the full open or full close position can cause damage to the door components.

3. Watch the panel closely while slowly jogging/rolling the curtain up on the drive shaft. Stop the door when you find the area where the quick-link attaches the long yellow Egress Strap loop to the yellow strap loop of the triangle panel piece.
4. Turn off the power switch located on the left side of the controller.
5. Unscrew the quick-link. Make sure not to drop the counter-weight into the door.
6. Access the inside area of the cooler/freezer box through the door opening. If the strap is hanging inside, carefully remove the Egress Strap (top center of door) from the door. Remove the gold cam buckle.

33.2 Installation

1. Ensure power has been turned off to the controller.
2. Un-roll the new yellow Egress Strap with attached gold cam buckle.
3. From the outside area, locate the roller assembly at the top center of the door where the original strap came into the curtain area from the inside cooler/freezer area. Use anything with some stiffness (banding material) and feed the stiff item through the roller and down through the slot located in the inside cooler/freezer area and tape or tie it to the small loop (not the D-ring) of the yellow strap. Gently pull it through the hole and roller assembly at the top/center of the door.
4. Ensure the yellow strap is not twisted. Place the counter-weight onto the yellow strap.
5. Attach the new strap loop to the yellow strap loop on the triangle panel piece using the quick-link.
6. Attach the new gold cam buckle to the door frame.
7. Turn the controller on and return to JOG mode, use the down arrow to lower the door to the floor. Exit JOG mode by holding the Up and Down arrows on the controller at the same time until you see "---" in the display of the controller.
8. Press "Open" button. If the Door is set to automatically close, door will time out and automatically close (if safety beams are clear). If the Door is set to manually close, press "Close" button and door should close.

Note: If the door does not lower to the Closed position, see 32.3 Resetting (Closing) The Door.

Note: If you detect any problems, STOP. Disconnect electrical power. Contact your distributor for assistance.

9. Press "Open" (and "Close" if required) several times to insure proper operation.
10. Re-attach the cover.

34 Removing and Replacing Floating Magnets or Velcro

NOTE: The door shown in the following illustrations may have different options and accessories than your door. Removing and replacing the floating is the same for all RollSeal units.

Diagram 34A

1. Turn off controller or remove power to the door.
2. Open the door to its upper limit. It will be necessary to raise the panel as high as it will go into the head unit. Refer to the appropriate Operator Manual (4801-5156 RollSeal SC-325 & SC-650 Controller Manual or the Manaras Installation and Instruction Manual). This will make it easier for you to remove and re-install the “Floating Magnets or Velcro and PIM Plate Assemblies” from the left and right side tracks (**Diagram 34A**).

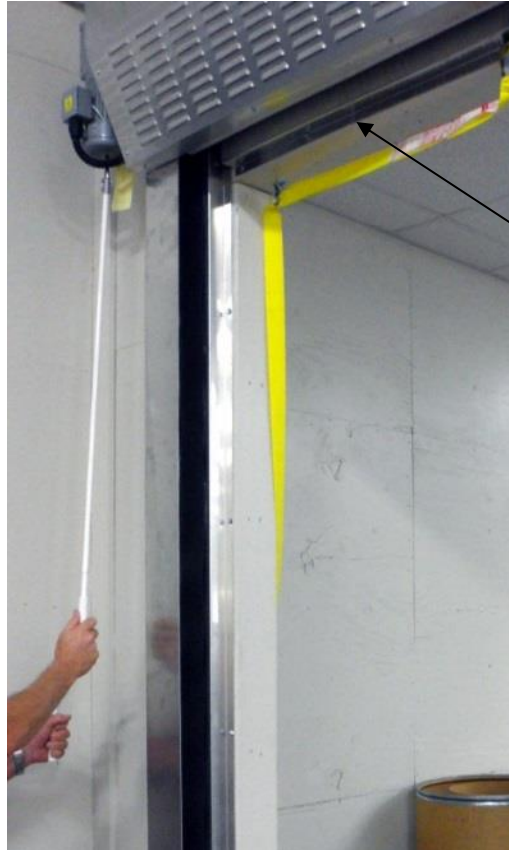

Ensure panel is raised into the head unit.

Warning!

Ensure power is turned “OFF” to prevent door movement while removing PIM Plate Assembly and Floating!

2. After you have raised the panel into the head unit, you can remove all of the PIM Plate nuts from both sides. Then remove the PIM plate and floating assemblies from their associated tracks (**Diagram 34B** and **Diagram 34C**).



Note: NSF Certified doors are equipped with a black rubber boot that covers the PIM bolts. Remove the black rubber boots to access the PIM nuts. Place the boots in a secure location for they must be replaced onto the PIM bolts after the Floating has been replaced.



Diagram 34B

Remove
all the PIM
nuts from
top to
bottom



Squeeze the
floating
around the
PIM Plate
and pull the
PIM
plate
assembly
and floating
out away
from the
track
assembly.

Diagram 34C

3. Lay the PIM plate assembly down on the floor and remove the old floating material from the PIM plate. Pay particular attention to the top of the PIM plate assembly. You will notice the material, at the top, has been cut at an angle. It will be necessary to re-install the new piece in the same arrangement as the one you have removed (**Diagram 34D** and **Diagram 34E**). Get the new piece of floating material. Flip the new piece upside down with the magnets or Velcro toward the floor. Align the pre-drilled holes of the material with the PIM bolts on the PIM plate assembly. You might find it easier to start at one end with the first PIM bolt, insert it, and then move to the other end slightly lifting the PIM plate in a bend to insert the PIM bolt at that end (**Diagram 34F**). Lay the assembly back down on the floor flat. This will slightly pull the material allowing the remaining holes to align properly. Proceed to insert the rest of the PIM bolts in their proper holes. Repeat the same steps for installing the floating to PIM plate for the other side.



Diagram 34D

Remove the "old" floating and discard. Re-install the "new" floating

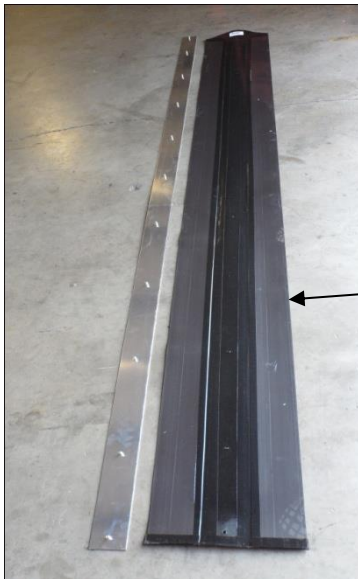

Diagram 34E

Lay the new floating next to the PIM plate with top of floating (Angled Cut) material to top of PIM plate. Flip the floating over the PIM Plate with magnets or Velcro against the floor then attach the floating over the PIM Plate Bolts



Re-install the "new" floating. It may be necessary to bend one end of the PIM plate up to attach onto the end PIM bolt.

Diagram 34F

- Grab and hold the PIM plate assembly and floating in a manner that will prevent the floating material from coming off of the PIM bolts. Re-install the PIM plate assembly in the track starting with the top PIM bolt. Align the PIM bolts with the holes in the track (Error! Reference source not found.). Firmly press the PIM bolts into their associated holes and attach the PIM nuts to the PIM bolts but do not tighten until all bolts have been installed. After all of the PIM bolts have been installed, tighten the nuts pulling the PIM plate firmly against the track. (Diagram 34H)

NOTE: Doors with a CMS unit have floating that requires slots to be cut in it to match the slots in the metal PIM plate. Use a razor knife to cut the fabric out of the slots. (Diagram 34J)

Squeeze the floating around the PIM Plate and push the top in the track assembly first. Align all PIM bolts with holes in the track assembly



Diagram 34G

After all of the PIM bolts have been installed, tighten the nuts pulling the PIM plate firmly against the track



Diagram 34H



Warning!

Do not over tighten!



Note: NSF Certified doors are equipped with a black rubber boot that covers the PIM bolts. Replace the black rubber boots on the PIM bolts that were removed in Step 4.

5. Repeat steps 1-4 above for the opposite side.
6. Manually lower the panel out the head unit to a position below the upper limits to turn off the safety switch and allow normal operation. **(Diagram 34I)**. Refer to the appropriate Operator Manual (4801-5156 RollSeal SC-325 & SC-650 Controller Manual or the Manaras Installation and Instruction Manual).
7. Restore power to the door.
8. "OPEN" and "CLOSE" the door several times to ensure smooth operation and proper setting of upper and lower limits



CMS EQUIPPED UNITS ONLY.
Cut out floating fabric where slots are located in the PIM plate to allow for air movement.

Diagram 34J

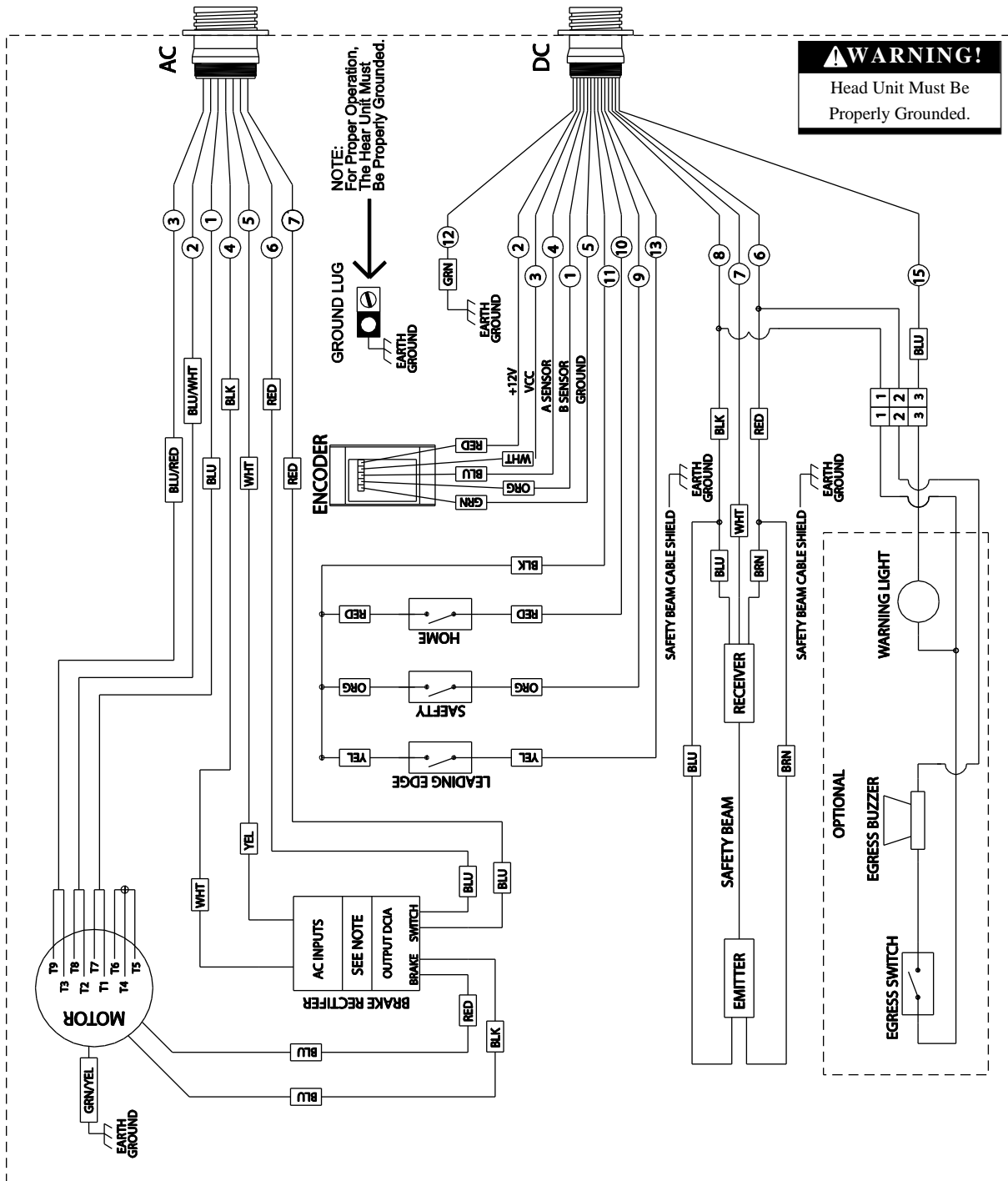

Diagram 34I

35 RS-500/600 Series Door Wiring Diagram (Brother Motor Only)

See Page 62

See Page 62



NOTE

If your serial # comes after '0010156', the wiring diagram changes from:
 Blue w/White Stripe changes from T8 & T2 to now use T9 & T3.
 The Blue w/White Stripe now uses T8 & T2.

36 RollSeal Smart Controller Wiring Diagram (Brother Motor Only)

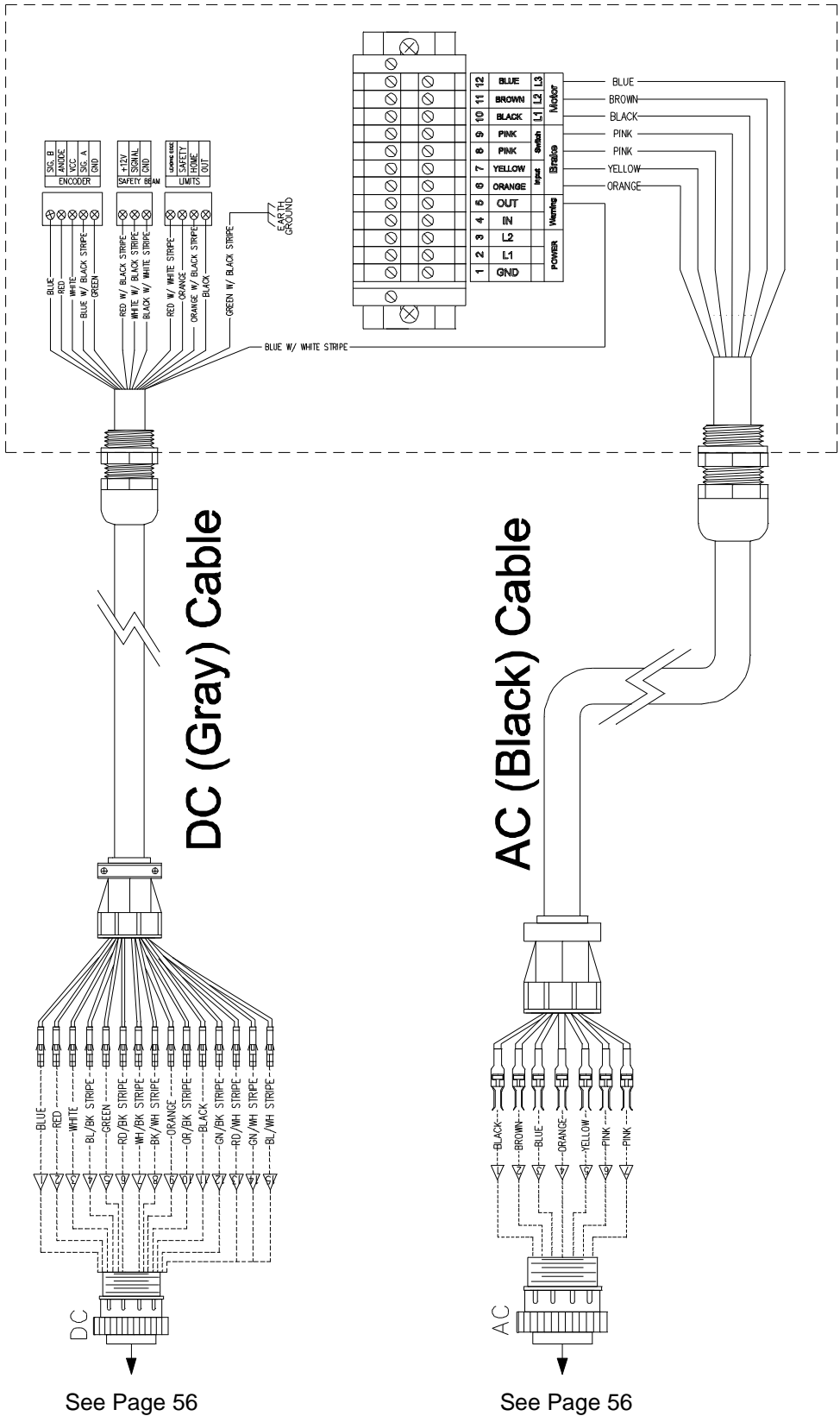

37 SC-325 Wiring Diagram

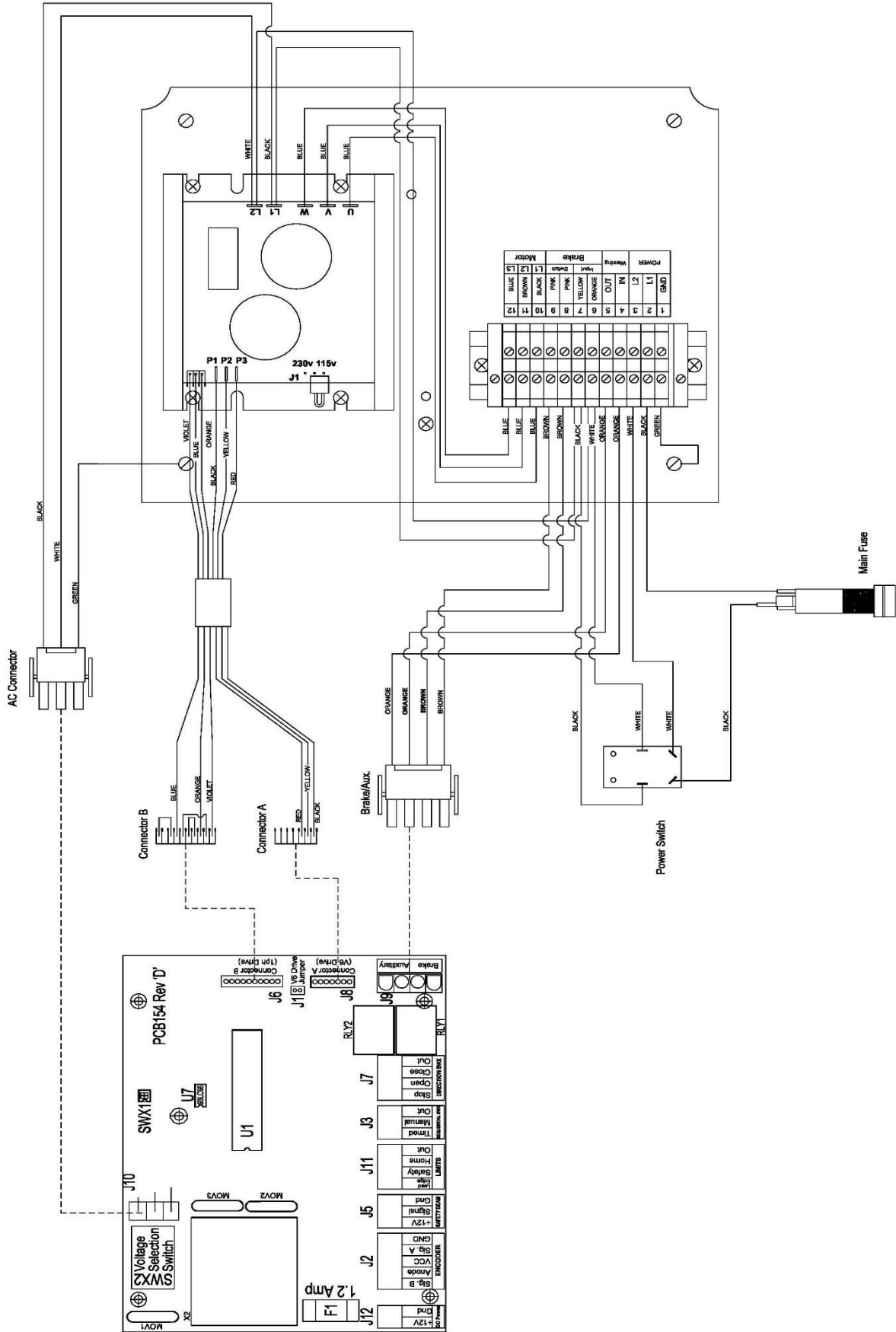

38 RollSeal CMS (Condensation Management System) Wiring Diagram



NSF Certified Doors are equipped with Left mount Brother operators, Smart Controller, and Magnetic Track Sealing System

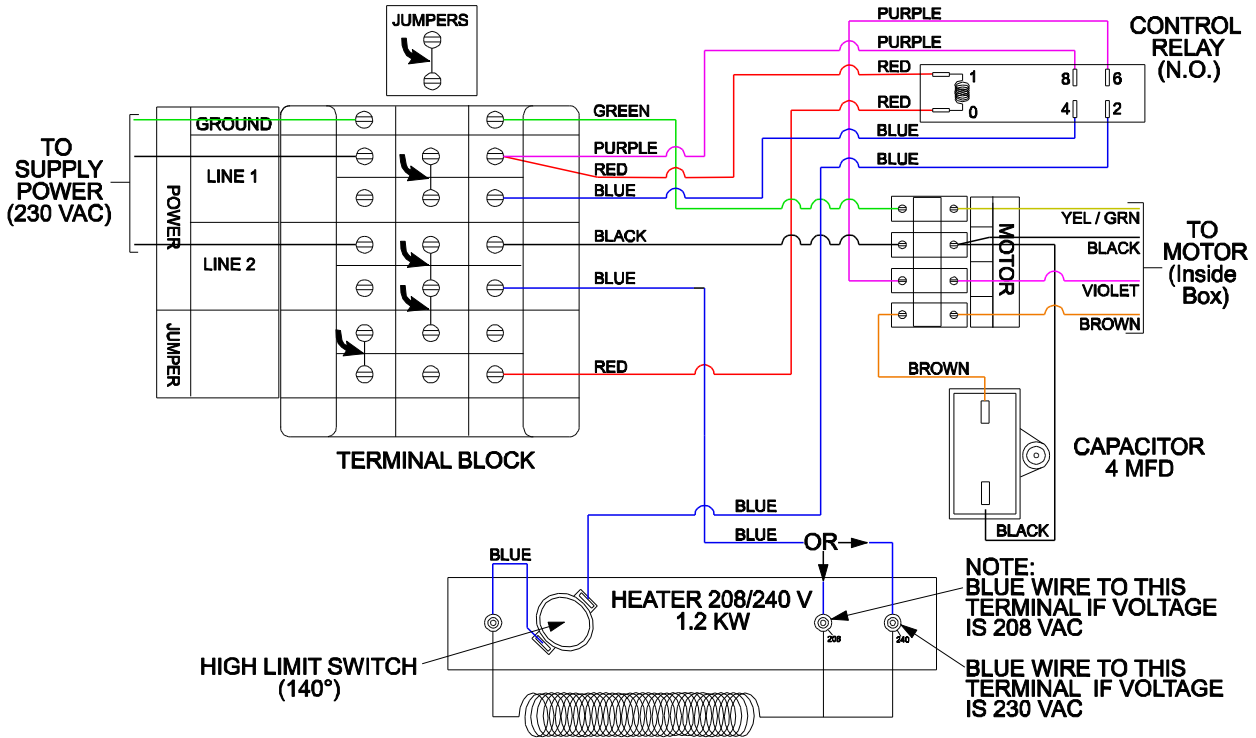

39 Wiring Optional Accessories

Motion Detectors, Infrared Sensors and Loop Sensors are optional accessories that can improve the efficiency and performance of your RollSeal Door. Sensors can also help prevent damage to the RollSeal Door by preventing the door from closing while lifts or objects are present in the vicinity.

Refer to the unit Owner's Manual for more information on installation, set-up and operation.

39.1 Wiring Falcon XL and EX Motion Detectors

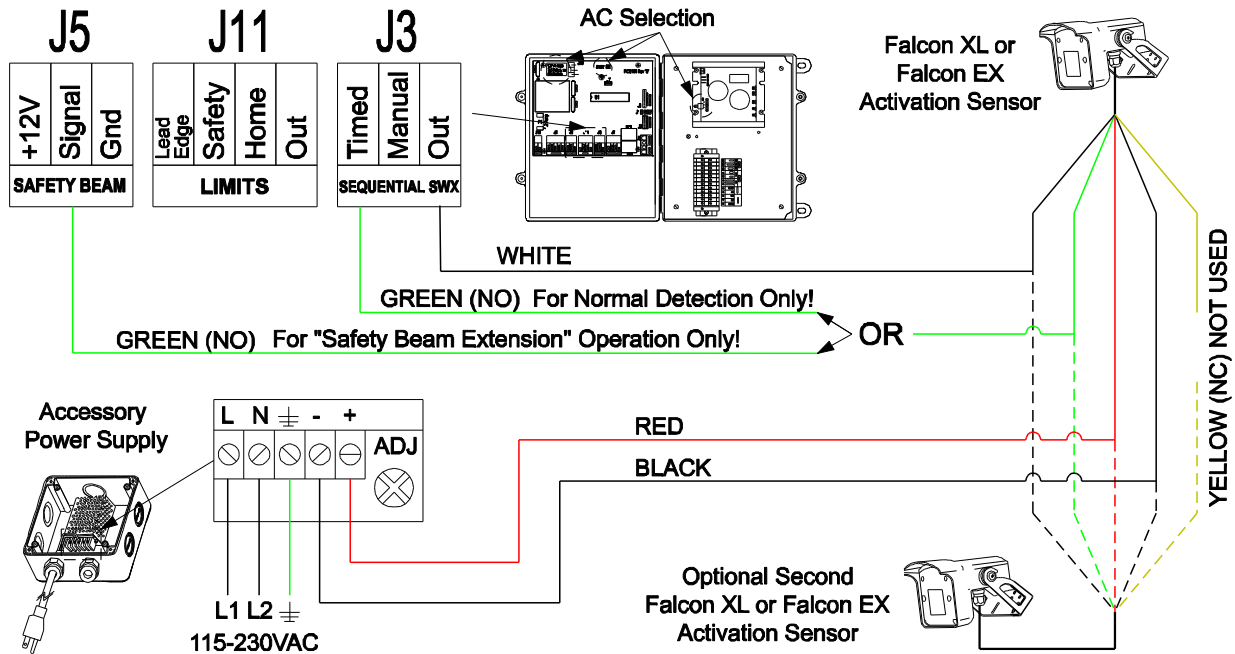

39.2 Wiring Falcon IS40 Infrared and Microwave Sensor

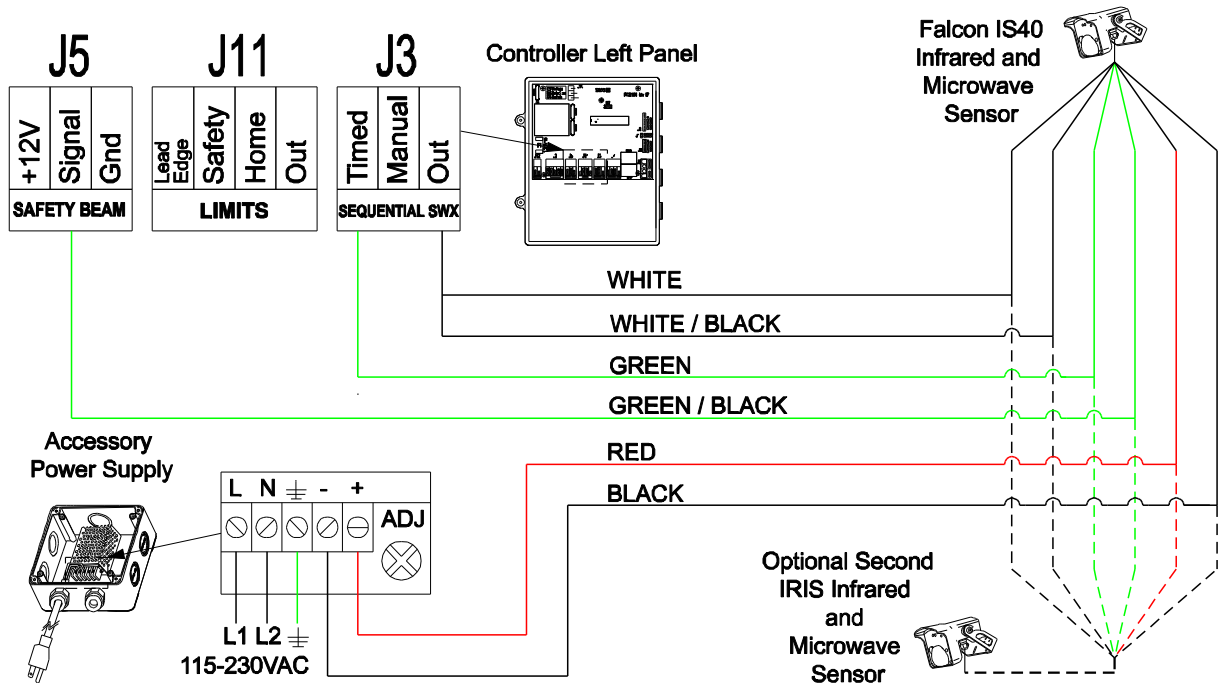

39.3 Wiring the IRIS Infrared and Microwave Sensor

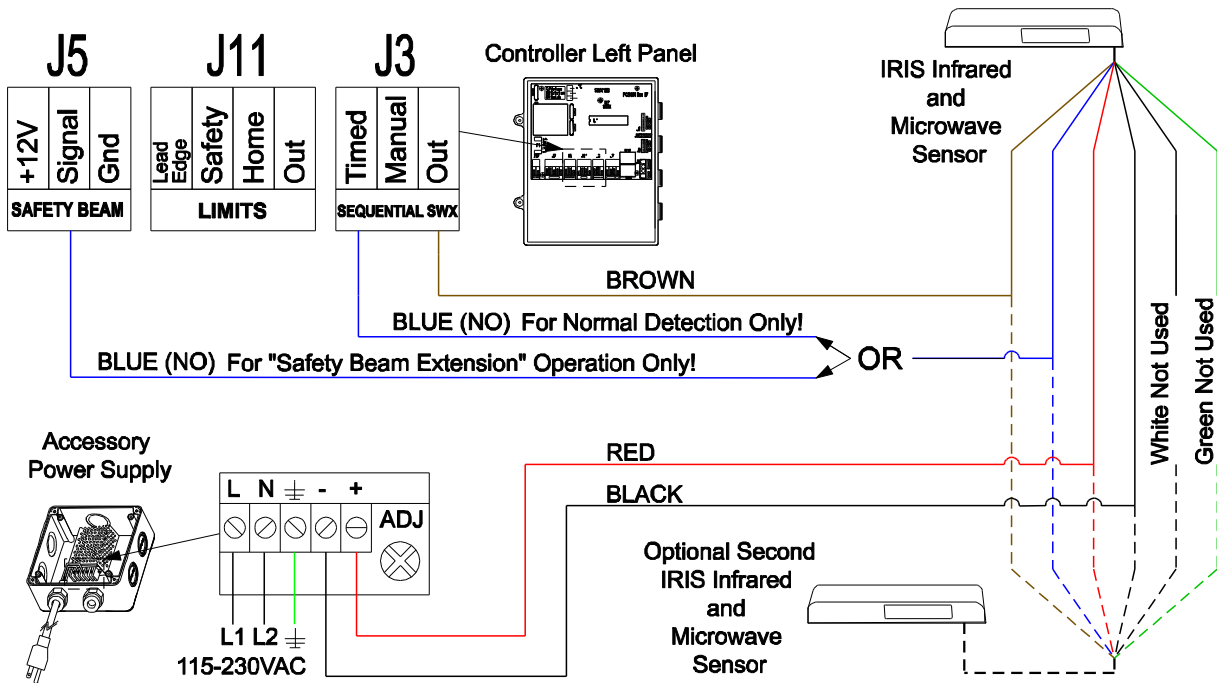

39.4 Wiring the Matrix2 Loop Sensor

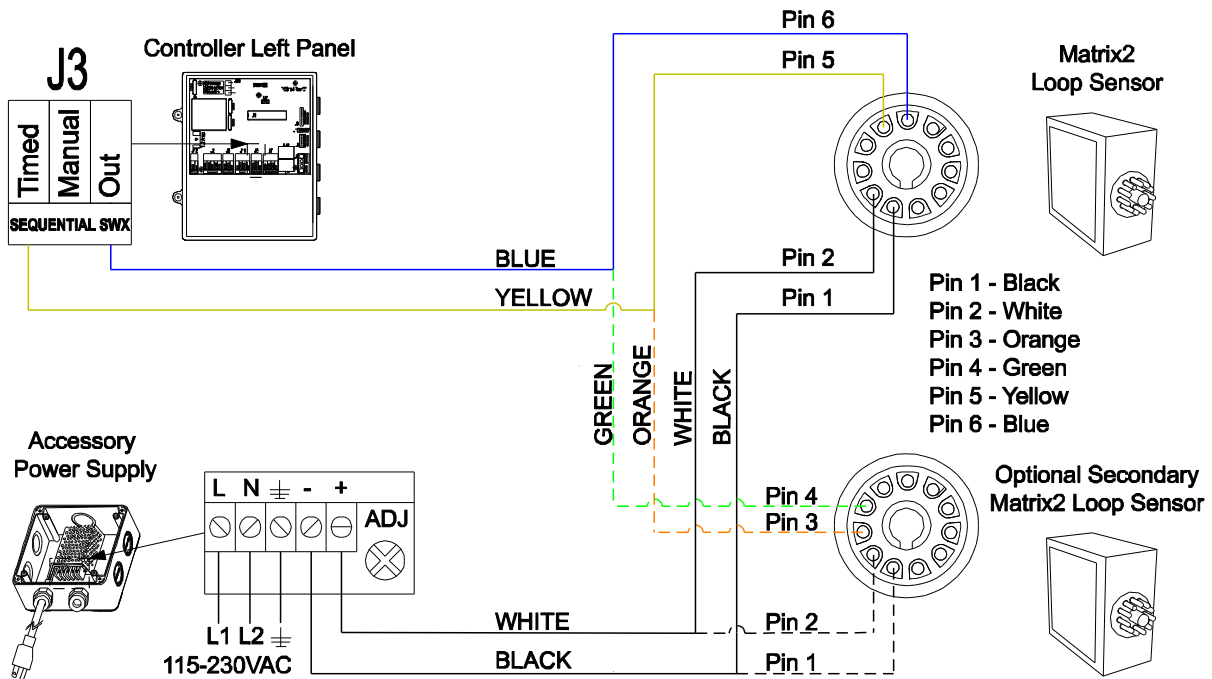

39.5 Wiring BEA Receiver and Brother Motor

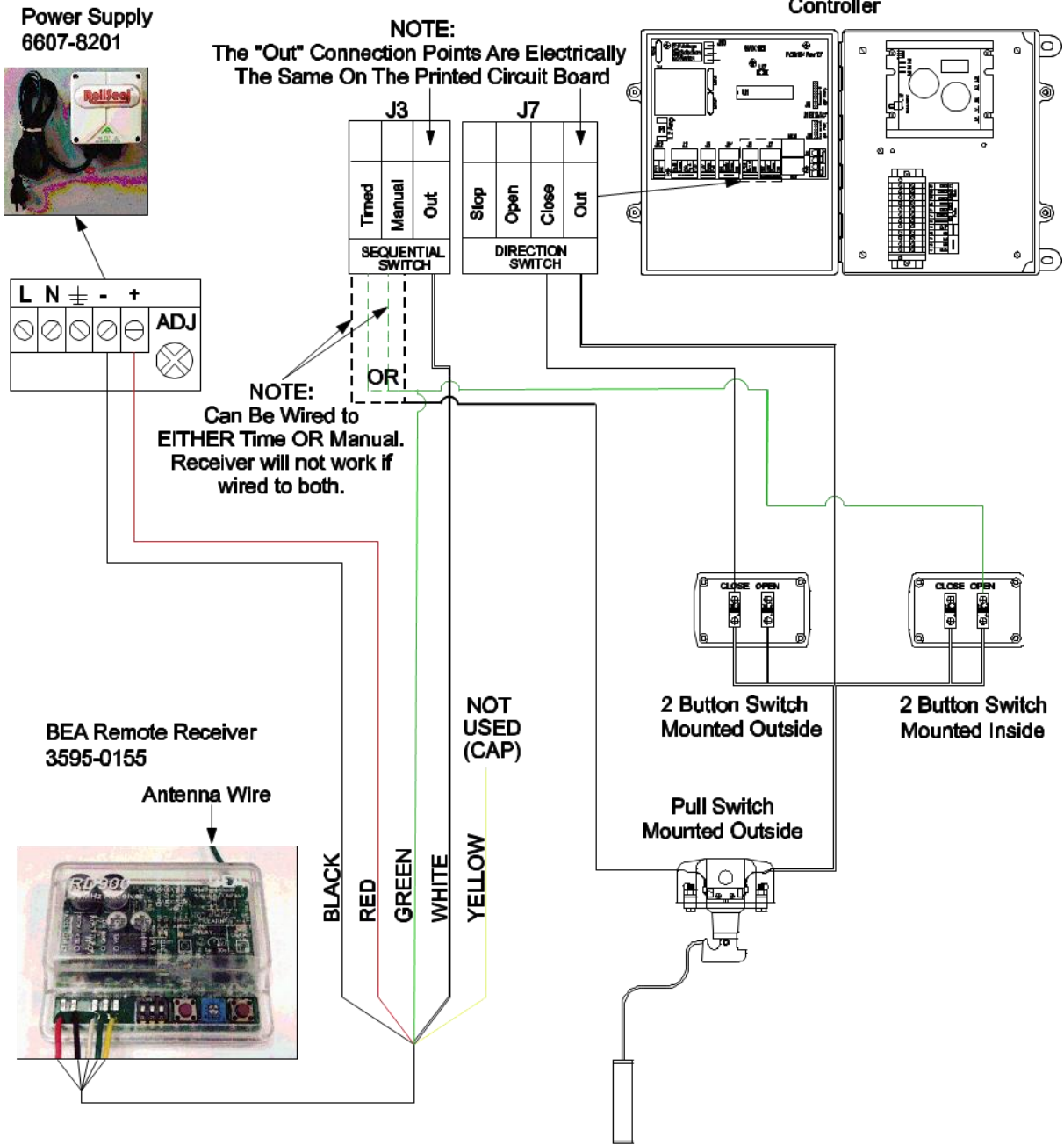

NOTE: Use 18 Gauge Wire for Switches and Seal All Open Areas With Silicone

40 Replacement Parts and Optional Accessories

40.1 SC-325 Controller

SC-325 Controls, Parts, and Accessories

Part Number	Description	Notes
Controller		
6607-8057	SC-325-V01-115	Use with RS-500 Doors ONLY
6607-8056	SC-325-V02-0 (Includes V2 Drive & Brake Module)	Use with RS-500 Doors ONLY
6607-8058	SC-325-V01-000-W01 (Includes W01 Switch Wiring Option with Conduit)	Use with RS-500 Doors ONLY
6607-8060	SC-325-V01-115-PLUS (Includes Prewired Controller)	Use with RS-500 Doors ONLY
6607-8061	SC-325-V01-230-PLUS (Includes Prewired Controller)	Use with RS-500 Doors ONLY

Drive Board Assemblies		
6407-6082	Use with SC-325 Controller 6607-8057, 6607-8058, 6607-8060, and 6607-8061 /PCB AC DriveKBVF-22D w/QA V1 (V1 Drive)	Use with SC-325 Controllers ONLY.
6407-6083	Use with SC-325 Controller 6607-8056 /PCB AC DriveKBVF-22D w/QA V2 (V2 Drive)	Use with SC-325 Controllers ONLY.
1902-4701	Drive Cable Assembly	

Chips		
3701-6069	PIC SC-325 RS Door Control V0.xx (Processor)	Use with SC-325 Controllers ONLY.
3540-0143	Double 'E' Chip	

Fuses		
3010-3001	FUSE 1.2 AMP 5mmX20mm slow blow (F1)	Located on PCB 154
3010-2140	FUSE 10 AMP 1/4X1-1/4 TD Main Fuse (Black Holder)	Use with SC-325 Controllers ONLY.

Brake Module & Rectifier		
6407-6088	Brake Module (Use with SC-325 Controller 6607-8056)	
3017-5052	Brake Rectifier (Use with 115 VAC Doors)	
3017-5050	Brake Rectifier (Use with 230 VAC Doors)	

Switches		
3001-2865	Main Power Switch w/toggle tabs	

Door Assembly		
6407-0618	/DOOR ASSY SC-325	Use with SC-325 Controllers ONLY.

40.2 SC-650 Controller

SC-650 Controls and Parts

Control	Description	Notes
6607-8100	SC-650-V01-0	Use with RS-600 Doors ONLY
6607-8101	SC-650-V02-0 (Includes V2 Drive)	Use with RS-600 Doors ONLY
6607-8102	SC-650-V01-115-PLUS	Use with RS-600 Doors ONLY
6607-8103	SC-650-V01-230-PLUS	Use with RS-600 Doors ONLY

Drive Board		
6407-6086	/PCB AC DriveKBVF-23D w/QA V1 (V1 Drive)	Use with SC-650 Controllers ONLY
6407-6087	/PCB AC DriveKBVF-23D w/QA V2 (V2 Drive)	Use with SC-650 Controllers ONLY
1902-4701	Drive Cable Assembly	

Chips		
3701-6071	PIC SC-650 RS Door Control V0.xx (Processor)	Use with SC-650 Controllers ONLY

Fuses		
3010-3001	FUSE 1.2 AMP 5mmX20mm slow blow (F1)	Located on PCB 154
3010-2994	FUSE 15 AMP 1/4X1-1/4 TD Main Fuse (Black Holder)	Use with SC-650 Controllers ONLY.

Brake Module & Rectifier		
6407-6088	/PCB Brake Module DBVF vr.9598	Use with SC-650 V1 & V2 Controllers
3017-5050	/A200 Brake Rectifier	Use with 230 volt AC Doors

Switches		
3001-2865	Main Power Switch w/toggle tabs	

Door Assemblies		
6407-0620	/DOOR ASSY SC-650	Use with SC-650 Controllers ONLY

40.3 Door Replacement Parts and Accessories

RollSeal Parts, and Accessories

Part Number	Description	Notes
Cable and Harness Assemblies		
1903-3053	HRNS RS-500 and RS-600 DC	
1903-3016	HRNS RS-500 and RS-600 AC	
1903-3064	HRNS RS-500 DC (Short)	
1903-3063	HRNS RS-500 and RS-600 AC (Short)	
1902-4701	Drive Cable Assembly	

Encoder		
1903-3113	HRNS HALL EFFECT 6P DEUTSCH	
6540-0089	D5/6 FLOATING HALL EFFECT ASSY	
6521-0065	D5/6 HALL EFFECT REST ASSY	

Safety Beam		
6450-9006	KIT RS500/RS600 PhotoEye Sensors (Omron E3FA)	Contains Both Emitter and Receiver

Door Switches		
1903-3050	Safety Switch	
1903-3051	Leading Edge Switch	
1903-3052	Home Switch	

Door Replacement Parts		
0401-7728	Leading Edge Switch Bracket	

Power Supply and BackUp Units		
3595-0109	Power BackUp 115 VAC	
6607-8200	Accessory Power Unit 12VDC 4.5A	
6607-8201	Accessory Power Unit 12VDC 1A	
6607-8202	Battery BackUp 230VAC 850VA	
6607-8203	Battery BackUp 115VAC	

Motion Detectors and Sensors		
3595-0108	Falcon XL	3595-0103
3595-0006	Falcon EX	3595-0104
3595-0127	Falcon IS40	
3595-0125	IRIS	
3595-0110	Matrix2	

Terminal Blocks		
3006-5076	2 Position Terminal Block	
3006-5077	3 Position Terminal Block	
3006-5078	4 Position Terminal Block	
3006-5079	5 Position Terminal Block	
3006-2984	2 Pin Mini Jumper	

Part Number	Description	Notes
Accessory Switches		
3001-7006	2-Button Close/Open Switch	
3001-7000	3-Button Close/Open/Stop Switch	
3001-6000	Ceiling Pull Switch CP1 SPST	
3001-6012	Ceiling/Wall Pull Switch	
6450-7640	Push Button Switch Kit	

Remote Operation		
3595-0155	Remote Receiver	
3595-0156	Remote Transmitter 1-Button	
3595-0157	Remote Transmitter 2-Button	
3595-0158	Remote Transmitter 3-Button	
3595-0159	Remote Transmitter 4-Button	

Manuals		
4801-5154	D5/6 Series Doors	

